

# *Traditional*

# *ROOFING*

Issue #6 Fall/Winter 2007

## *The Owner-Built Century Roof*

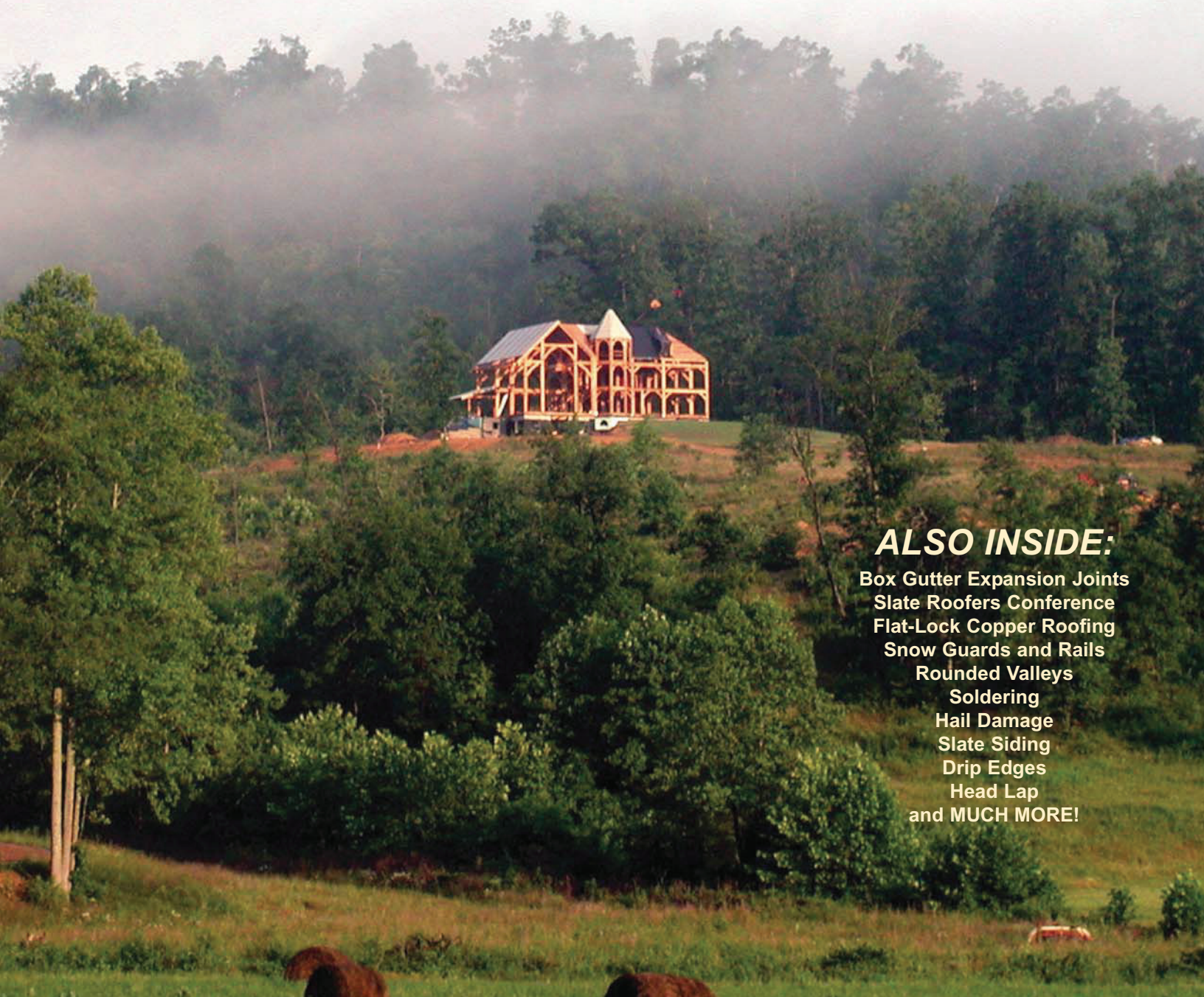

### ***ALSO INSIDE:***

Box Gutter Expansion Joints  
Slate Roofers Conference  
Flat-Lock Copper Roofing  
Snow Guards and Rails  
Rounded Valleys  
Soldering  
Hail Damage  
Slate Siding  
Drip Edges  
Head Lap  
and MUCH MORE!



# We're virtually unknown to each other but, we'd like to *Thank You!*

**S**late roofing contractors, architects, owners, consultants, preservationists—all who have had a part in the selection or installation of the 200,000 + squares of Vermont Black roofing slate that we have produced over recent decades—  
we *Thank You!*

Why are we extending our gratitude to you when we're virtually unknown to each other? Because, until now, we have always sold our Vermont Black roofing slate, along with our other colors, through distributors. We never knew where our roofing slate went.

We would like you to know that we now also sell directly to roofing contractors, owners, and other end users.

So, you can see why connecting to you is important to us. We hope you will feel the same way.

Dedicated to preserving this age-old art of quarrying, producing, and installing our hand split roofing slates, we support our roofing contractors with top rate personalized service at an attractive price.

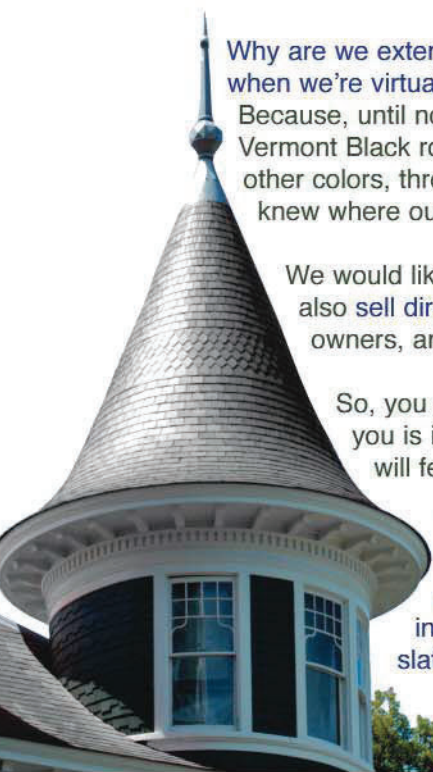

As we become acquainted, please know that we are passionate about our products and appreciative of your part in placing our Vermont Black roofing slate on thousands of buildings around the Country.



In addition to our vastly popular Vermont Black roofing slate, we currently produce two additional colors:



Vermont Black



Vermont Hazy Green



Vermont Strata Grey

**W**e're excited about getting to know you, serving you, and seeing the buildings on which our products are installed. Please visit our website, email us or give us a call anytime. We'd like to hear from you.

[www.realvermontroofingslate.com](http://www.realvermontroofingslate.com)

[susan@realvermontroofingslate.com](mailto:susan@realvermontroofingslate.com)

802.645.0100



720 Rte 149  
West Pawlet, VT 05775

Real Vermont Roofing Slate is the sales division of Newmont Slate Co., Inc., the largest U.S. producer of Vermont Black Roofing Slate



# Features:

TRG 2007

## Headlap

This fundamental and critical roofing concept is often overlooked or ignored.

4

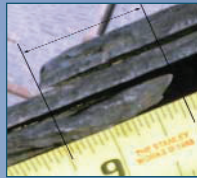

## Flat-Lock Soldered Copper

A traditional low-slope roofing that lasts for generations, but is rarely seen in roofing circles today.

6



## SRCA Conference 2007

The Slate Roofing Contractors' Association of North America holds its first national conference.

8



## Rounded Slate Valleys

A beautiful way to create a unique look on a slate roof.

10



## Slate Siding

This often overlooked method of protecting the outer walls of a structure can be extraordinarily artistic.

14

Photo by Jorn Wichert

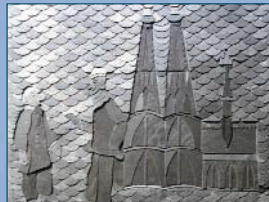

## Expansion Joints in Built-In Gutters

Important but obscure details can make or break a box gutter.

16



## The Owner-Built Century Roof

Once again, a home-owner with no prior slating experience outdoes the roofing contractors.

20

Photo by Thomas Massie



## Project Spotlight

The Paulin Slate and Copper Company shines at Case Western University.

22

Photo by Christopher Paulin



## Soldering Roof Flashings

An important skill when doing advanced flashing work.

26



## ALSO IN THIS ISSUE:

Bits and Pieces 2

Readers Write 12

Generation X Slaters 27

What the Hail? 29

Snowguards 31

Old Chimney Removal 31

Metal Drip Edges 32

Aprons and Snow Rails 36

### CONTRIBUTORS:

Barry Smith, Brent Ulisky, Liam Tower, Thomas Massie, Christopher Paulin, Joseph Jenkins

Special thanks to Jorn Wichert for photos of German slate siding.

Editor/Design/Layout: Joseph Jenkins  
Editorial Volunteers: Barry Smith, Joseph J. Jenkins, Jeanine Jenkins

Please pass this issue on to an interested reader after you've finished with it!

Weathervane on St. John's Episcopal Church slate roof, Roanoke, VA

Photo by Joseph Jenkins

### TRADITIONAL ROOFING MAGAZINE • TRADITIONALROOFING.COM

Copyright © 2007 by Joseph Jenkins, Inc., All Rights Reserved  
Published on an unscheduled basis by Joseph Jenkins, Inc., 143 Forest Lane, Grove City, PA 16127 USA.  
8,000 copies of this issue were printed. All articles are posted on the web for free access at traditionalroofing.com after the print issue has been circulated.

Portions of this publication may be reproduced subject to the following conditions: 1. The information must not be changed or altered; 2. Joseph Jenkins, Inc., 143 Forest Lane, Grove City, PA 16127 USA, ph: 814-786-9085 is credited as the source; 3. The reproduction is not done for profit without express written permission from the publisher.

TR is an advertiser supported magazine distributed free to contractors, homeowners, architects, historical and preservation societies and traditional roofing industry professionals across the United States, Canada and Europe. Letters and submissions are welcome. Please direct all correspondence to:

Traditional Roofing, 143 Forest Lane, Grove City, PA 16127 USA  
Ph: 814-786-9085; Toll Free: (866) 641-7141; Fax: (814) 786-8209  
Email: editor@traditionalroofing.com; Visit our web sites at: traditionalroofing.com and slateroofcentral.com

All Uncredited Photos by Joe Jenkins

## On the Cover:

The Thomas Massie timber-frame home under construction in Kentucky.  
Cover photo by Thomas Massie.

# Advice from Experience

Ross A. Gibson

As a third generation master carpenter, I have learned many tricks of the trade. Some techniques were passed down from my father and grandfather. Others I learned from my own trial and errors. While recently celebrating my 55th birthday, I reminisced about the 40 years I have spent in construction. I would like to share with you one of the tricks I believe is a good idea.

I was 17 years old when my father told me to paint the valley of a very steep slate roof. It didn't take long to realize that I needed three hands to complete this task. I needed one hand for the paint brush, one hand for the paint bucket and one hand to hold on for dear life. My father believed in the school of hard knocks, so he let me climb the valley with two hands when I needed three. I made a mess.

Today I get a sturdy plastic jug with a handle, then drill a 3/16 hole in the top. I tie one end of a two foot string to the handle and the other end to my belt. Now I can climb with two hands, squirt the valley paint where I want with no fuss, no muss. At the end of the job, I insert a roofing nail in the hole then turn it upside down for a few seconds to seal it for the next valley or chimney flash. My father would be proud.



Photos supplied by Ross Gibson

## WEB SITE DEVOTED TO CANCER PREVENTION

I am creating a web site devoted to cancer prevention for roofers working with modified bitumen and EPDM membranes. For more information about possible health effects from exposure to asphalt and about the selection of appropriate respiratory protection, see the following publications: NIOSH [1987]. NIOSH respirator decision logic. Cincinnati, OH: U.S. Department of Health and Human Services, Centers for Disease Control, National Institute for Occupational Safety and Health, DHHS (NIOSH) Publication No. 87-108; NIOSH [1996]. NIOSH guide to the selection and use of particulate respirators certified under 42 CFR 84. Cincinnati, OH: U.S. Department of Health and Human Services, Public Health Service, Centers for Disease Control and Prevention, National Institute for Occupational Safety and Health, DHHS (NIOSH) Publication No. 96-101; NIOSH [2000]. Health effects of occupational exposure to asphalt. U.S. Department of Health and Human Services, Public Health Service, Centers for Disease Control and Prevention, National Institute for Occupational Safety and Health, DHHS (NIOSH) Publication No. 2001-110. Here is where I will be storing the results of my research: [www.milwaukeerenaissance.com/DailyAgoraAnnouncements/HomePage](http://www.milwaukeerenaissance.com/DailyAgoraAnnouncements/HomePage). James J. Godsil, President — Community Roofing & Restoration, Inc.

## MYSTERIOUS STAINS *Joseph Jenkins*

We have received photos in the past year of two slate roofs in the southern U.S. that have developed large splotches of mysterious black stains. There have been a number of theories as to the origin of the stains, such as mold or other types of growth, felt paper or some type of underlayment deterioration, but the true cause of the stains has yet to be determined.

Pat Bryan, of Knoxville, Tennessee, for example, wrote, "Over the past 10 years, a black substance has been spreading on my 20-year-old, north-facing slate roof. It doesn't scrape off. I tried spraying a test patch with a 50% chlorine solution, but no change."

My response to Pat was, "What strikes me as odd about the stains is that none of them appear to originate in the center of a slate. If they were caused by a mold or fungus, you would think they would exist right in the center of a slate somewhere. Can you check to see whether the installers placed felt paper between every course of slate? I have seen this done. It's a mistake. It's possible that a low grade of asphalt from the felt paper is leaching onto your roof. Perhaps the leachate is feeding some strain of mildew."

Pat discovered a solution to the problem. "I just thought I'd let you know that, while I didn't determine the cause of it, I did find a good method to get rid of it — at least temporarily. Chemicals (chlorine, copper) didn't seem to have any affect, so I pressure-washed it off using a 24' extension pole and a 12.5" wall washer from Northern (Model WW320t). This wall/roof washing attachment has a brush edge and two rotating nozzles. The unit virtually floated over the slate, and the nozzles weren't aggressive enough to damage the roof." The before and after photos are shown at right.

Pat later informed me that, "FYI, while I was repairing some slate tiles yesterday, I noticed that there IS felt paper between the courses. I had previously said there wasn't because I couldn't see any from the roof edges. Perhaps this is contributing to the black growth on the north faces."

I wonder if the felt is somehow creating the problem. Felt is typically only installed underneath slates, not in between courses, but sometimes a roofer will install it that way because he doesn't really know what he's doing. The black growth the roof is exhibiting is very unusual, which is why I suspect some deviation from standard installation practices that may be at the root of the problem. In any case, I'm glad Pat found a solution.

Any readers have any experience with anything like this? If so, let us know: [editor@traditionalroofing.com](mailto:editor@traditionalroofing.com).



Photos by Pat Bryan



Photos supplied by Martin Bungartz

## SLATE ART

Martin Bungartz (left), SRCA member and German immigrant living in Florida, shows off some of the highly skilled "slate art" for which the Germans are famous. He can be contacted at Technical Management, Inc., 11233 60th Avenue N, Seminole, FL 33772; Ph/Fax: 727-392-0860; email: [m.bungartz@gmx.net](mailto:m.bungartz@gmx.net)

# Real Vermont Roofing Slate

Susan Wonderly

NEWMONT SLATE CO., INC., the largest quarry and producer of roofing slates in the United States, opened a direct sales division, Real Vermont Roofing Slate, last spring and on the 19th of this month launched its first website. Prior to 2007, Jack Williams, President and CEO of Newmont, sold his roofing slates exclusively to distributors for 43 years. As a result, although its roofing slate tops thousands of institutional and residential buildings across the United States, this



Photo by Susan Wonderly

Vermont based company is virtually unknown to roofing contractors, architects, and owners. Determined to publicly connect Newmont Slate to its superior products, including its vastly popular Vermont Black roofing slate, Williams has begun an all-out advertising campaign.

Newmont Slate is focusing on three distinctive markets: institutional, residential, and log and timber frame homes, and other areas of specialty application. Researching many aspects of geographical locations prone to fires such as California, Colorado and New Mexico, Newmont will market its roofing slate as an aid in fire prevention because slate qualifies as a non-combustible building material.

Additionally, Newmont is taking steps to obtain green certification for its slate product. Ed Mazria AIA, a real veteran of green design, recently told a Newmont staff member that he thought its hand-split roofing slate would be a natural for green certification. Mazria said, "As far as I know, roofing slate is produced with a low energy quotient, it will last for 100 or more years, and it's recyclable." Those words of encouragement from an architect of international authority inspired some of the new directions Newmont is taking.

When asked about the [new for Newmont] direct marketing, Williams says, "We have a responsibility to remain flexible, to go with the flow, and to do the right thing. It's how we respond to changing conditions that makes a difference. Besides which, gone are the days when distributors would place orders on Mondays, pick them up on Fridays, and pay on Tuesdays. Changing times are challenging, but we're learning a whole lot more that we didn't know before. Plus, there is something ultimately gratifying about seeing a photograph of a beautiful building with our product on it. Before, we didn't have the opportunity to connect with our end users. We never knew to whom our roofing slate was sold. In the end, it's all worth it. The service aspect of this business hasn't changed, however. It's always been the backbone of our business, and always will be. We're just beginning to connect with architects, roofing contractors, and owners — and that's a good thing."

Behind Newmont Slate's heretofore quiet success is the ability to produce a minimum of fifty thousand square feet per week and maintain quarries of large acreage with ample deposits of good quality stone.

Equally, Williams stores orders at the quarry at no additional charge until they are needed on the construction site. This policy is particularly attractive to construction sites faced with limited storage or contractors who simply wish to diminish work-site vandalism or theft. Williams accommodates all architectural specifications regardless of the widths, lengths or thickness of slates from thins to heavies in a variety of colors. The standard colors of Newmont's slate are Vermont Black, Vermont Strata Grey and Vermont Hazy Green. Their new website is [www.realvermontroofingslate.com](http://www.realvermontroofingslate.com)

## STANDARD PRACTICES FOR STAINLESS STEEL Roofing, Flashing, Copings

This 13 page "designer handbook," which can be downloaded on the internet as a PDF file, contains useful information about using stainless steel as a roofing material. The contents include: Properties of Stainless Steel, Standard Practices, How to Select Stainless Steel, General Shop Practices, Joining, Installation Practices, Standing Seam Roofing, Copings, Expansion Joints, and several other chapters. Available from the Specialty Steel Industry of North America, 3050 K Street, N.W., Washington, D.C. 20007; phone: 800-982-0355; and on the web at [www.ssina.com](http://www.ssina.com). Excerpt: "Properties of Stainless Steel: Stainless steel is

perhaps best-known for its aesthetic value and long life. For most roofing and flashing applications, however, functional properties and economic factors are also important. Stainless steel for such applications offers significant performance advantages to the architect and building owner:

- Stainless steel is corrosion resistant all the way through and requires no artificially applied surface coating for protection.
- Stainless steel is self-cleaning and requires little or no maintenance and is often the most economical material when total life cycle costing is considered.... [etc.]"

	EXPANSION IN 64ths OF AN INCH PER 100° F TEMPERATURE RISE PER 10' LENGTH (APPROX.)												
	1	2	3	4	5	6	7	8	9	10	11	12	13
STAINLESS													
SOFT COPPER													
C.R. COPPER													
TIN													
ALUMINUM													
LEAD													
ZINC													

A



James Warden engaged in volunteer slate repair in New Orleans' Katrina-ravaged Lower Ninth Ward.

Photo by Joseph Jenkins

Winner of our **best tip award** this issue is SRCA member James Warden of Milligan Construction in Providence, RI. If you're on a roof with thicker slates or even tiles and a standard slate hook isn't big enough, just flip it over, close the hook end into a loop, nail it through the loop and bend the longer end up to make an oversized hook. Pretty slick. James gets a free Gilbert and Becker slate hammer!

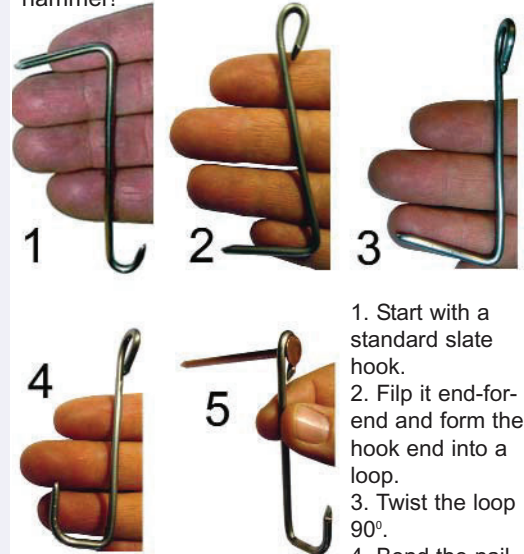

1. Start with a standard slate hook.
2. Flip it end-for-end and form the hook end into a loop.
3. Twist the loop 90°.
4. Bend the nailing end into a hook shape.
5. Use a nail through the new loop to attach the slate hook to the roof. Now you have an oversized hook that can be used on thick slates or tiles!

### SLATE HOOK REPAIR

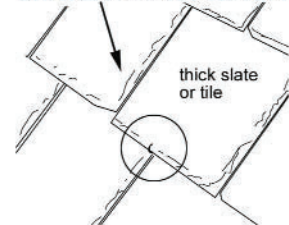

Have a great roofing tip? Email it to: [editor@traditionalroofing.com](mailto:editor@traditionalroofing.com) or mail it to us! You could be the next winner of a traditional slater's hammer worth \$100.00!



# HEADLAP

JOSEPH JENKINS

INSUFFICIENT HEADLAP. ZERO HEADLAP. NEGATIVE HEADLAP. These are all words that should send a chill up the spine of any good slater. There are few details on a slate roof installation that, if done wrong, will cause the entire roof to be condemned and have to be removed and done all over again. Headlap is one of them.

As a slate roof consultant, I have the opportunity to travel the country and look at newly installed slate roofs, many unfortunately riddled with glaring installation mistakes. I always check the headlap first. If the headlap is OK, then the roof installation has hope. If the headlap is missing or inadequate, the roof is doomed.

What exactly is headlap? I'm glad you asked that question. Many contractors will take on a slate roof installation project with little or no experience and, amazingly, will forge ahead with the job without doing any research or attempting to gain any education whatsoever about slate roof installation. This is despite the fact that a couple hours on the internet will yield a wealth of information about slate roofs. Much of that information is available at TraditionalRoofing.com, but there is also much more at SlateRoofCentral.com. So some curiosity is always welcome.

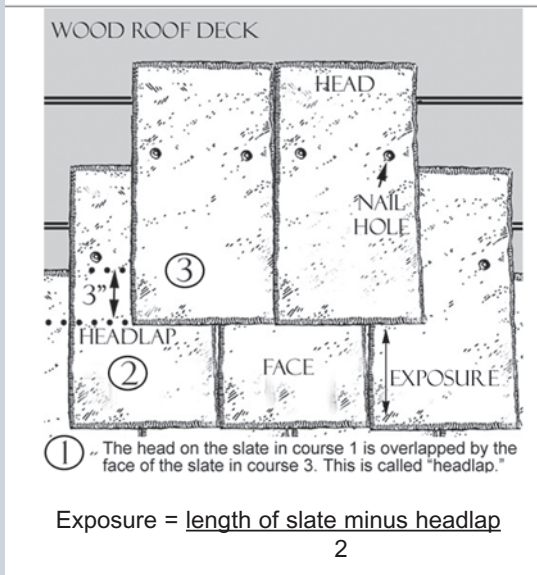
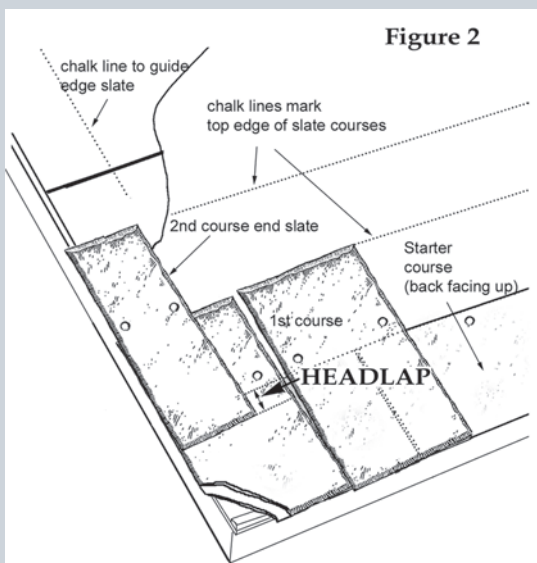
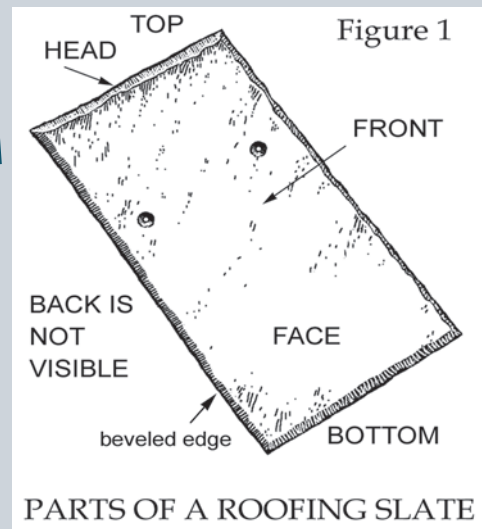

If a contractor doesn't understand the principle of headlap, he or she should not be installing a slate roof until that simple principle is completely digested and absorbed. Let's start with the basics. Every piece of roofing slate has a front and back, top, and bottom, when being used on a standard American style slate roof (Figure 1). The bottom, front (often called the "face") is what you see after the slate has been installed on the roof. The back of every slate faces the roof (except on the starter course, but that's explained in Traditional Roofing #5). The back does not show the beveled edges of the slate nor does it have indented (countersunk) nail holes. The front of every slate faces the sky and shows the beveled edges and indented nail holes. The top of the slate is covered by the overlying slates. The very top of the slate is called the "head." When one slate overlaps another, that's called overlap. Pretty simple. When the head of a slate is overlapped by the slate two courses above it, that's called headlap — that's the critical overlap on a slate roof (Figure 2). Headlap is what keeps the water from penetrating through the roof. Headlap is essentially what renders the roof water-tight. If there is no headlap, the roof will leak.

Standard headlap these days is 3", however, the headlap varies according to slope (Figure 3). When the slope drops, water drains more slowly, so more water-tightness is required. This is achieved by simply increasing the headlap to 4". Slate roofs should not be installed below a slope of 4:12 (4 feet of rise on 12 feet of run). In fact, the best slate roofs are installed on slopes too steep to walk upon (8:12 or above). However, if you must install slate on a lower slope, then from 4:12 up to 6:12, a 4" headlap is recommended. Extra headlap never hurts a roof, so 4" headlap is often recommended up to an 8:12 slope. 8:12 and above can use a 3" headlap, which *can* even be dropped to 2" when the roof is really steep. These are standard industry recommendations today. Having said that, however, there are many slate roofs 100 years old with only 2" of headlap with slopes down to an 8:12. The problem with installing slate with 2" headlap is that the layout of the slate courses requires precision in order to maintain a consistent 2" headlap throughout the field of the roof. If the slates are not installed along a chalk line, the courses can go wavy and you can lose your headlap altogether (Figure 7). Better to install the roof with a 3" or 4" headlap and not worry about cutting corners.

The reason contractors do cut corners with headlap is because it uses less slate. It also reduces the weight of the roof. Neither of these two factors is justification for installing a slate roof with inadequate headlap. Better to err on the side of caution and install a roof with extra headlap, than skimp and risk having to remove the entire roof and start over. Figure 4 shows a roof that was installed with negative headlap. Such a roof is like a sieve, designed to allow water to pass through it. This was a new slate roof on a college dormitory. Figure 5 shows a roof with little or no headlap — another disaster. Headlap is hard, if not impossible, to spot on a roof when looking straight at the field of the roof. However, if you can look at the gable end, the headlap, or lack thereof, is as clear as day (Figure 6).

There are times when extra headlap is valuable. These include when slate is

Continued On Next Page

installed in ice-dam prone areas of the roof, such as along eaves. If ice-damming is a serious consideration on your project, increase the headlap along the eaves by an inch when installing the slate. Extra headlap can also help with wind resistance. The extra overlapping makes for a tighter roof, one less likely for wind to get underneath the slates.

The roof calculations are simple enough. If you subtract the headlap from the length of your slate, then divide the remainder in two, you have your slate exposure or course spacing. For example, a 20" long slate with a 4" headlap would have an 8" course spacing ( $20" - 4" = 16" / 2 = 8"$ ). Course spacing, or *exposure*, is what you see of each course on the roof. Typically, a slate roof is installed by chalking the top of each and every slate course, then nailing the slate to the roof along the chalk lines. In the example given above, there would be a chalk line every 8" up the field of the roof. The top, or head, of the slate would align with the chalk line. The second course of slates above would then overlap that head by 4". Voila! Headlap!

Before you run out and start chalking 8" lines up a roof for 20" slates, let me remind you that the starter course, first course, and often second course will be chalked on a different measurement. You can read about starter courses in Traditional Roofing #5.

When ordering slates for a project, you should know your headlap ahead of time and order the slates accordingly. For example, a 10"X20" slate requires 170 slates per square (a "square" is 100 square feet of roof coverage) when installed with a 3" headlap, but requires 180 slates per square when installed with a 4" headlap. Furthermore, you want to make sure the slates are manufactured with the nail holes in the right place. The nails should be installed just above the head of the underlying slate. In the example given above, the nail holes must be a minimum of 12" from the bottom of the slate (8" exposure plus 4" headlap), but 13" would be better because it would give you some extra clearance. If the nail holes are too low, you'll be nailing through the head of the underlying slates, and that's a no-no. I only mention this because you may want to install a slate roof with even more than 4" of headlap on a lower slope situation, so you'll have to watch your nail placement as most slates are manufactured to be installed with up to a 4" headlap.

It's not as confusing as it sounds. Study the illustrations in this article and you will see that headlap is really a simple concept as well as a critical element of a slate roof. You will also find that, once you understand headlap, you can make a roof out of anything that can be made into a flat shingle, not just a piece of stone. Cut the ends off a beer can, cut down one side of the can, flatten out the remaining piece of aluminum, and you have a beer can shingle. Make a bunch of them, install them with correct headlap, and you have a beer can roof! Just think of all that beer you'd have to drink though. Bummer. ☹️

**Figure 3**  
Recommended Roof Slopes for Slate Roofs  
(showing minimum headlaps)

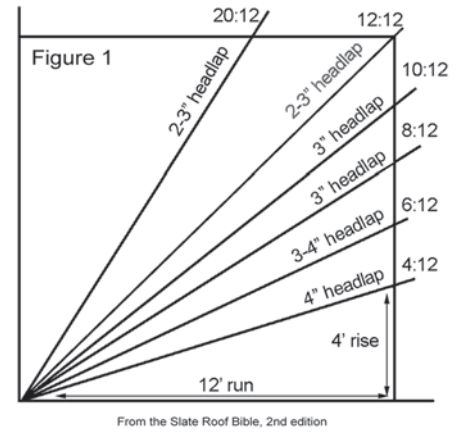

One inch headlap on this shopping center roof in Covington, LA, just doesn't quite cut the mustard. This new roof must be removed and reslated. 📏

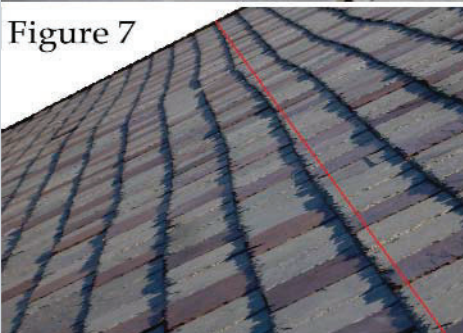
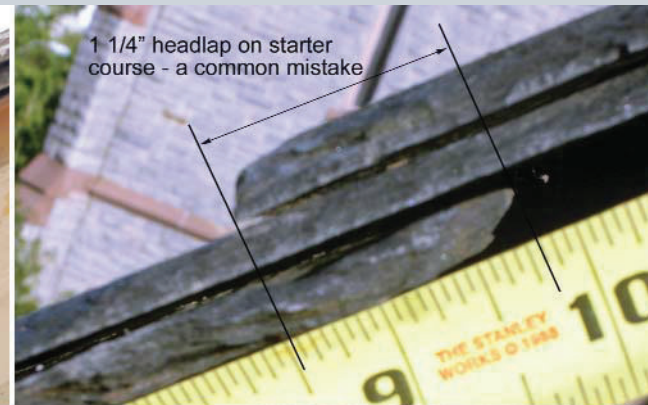
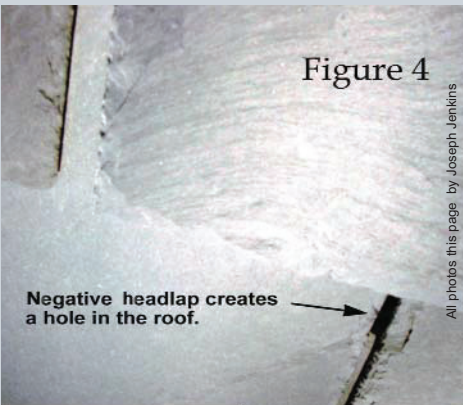

**EXAMPLES OF HEADLAP ERRORS**

Clockwise from top left: F4: An inadequate starter course has created "negative headlap" at the worst place on the roof — near the drip edge where the roof takes the most water. F5: The same starter course, on a college dormitory in Pennsylvania, showing inadequate headlap. Top, right: The problem of inadequate headlap on the starter course is more common that it should be. Here it is shown on a church in Virginia. F6: No headlap at all on the entire roof of this historical building in Georgia cost \$450,000+ to remedy. F7: The wavy nature of the courses on this Louisiana shopping center roof show how headlap can be lost by sagging lines. Install slate along straight, accurate chalk lines for best results.

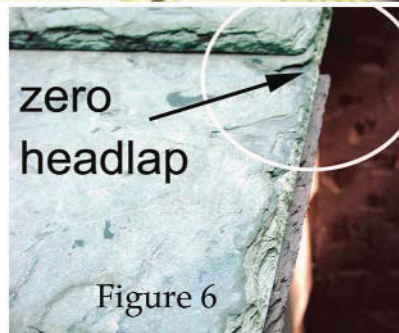



# Flat-Lock Soldered Copper Roofing

Barry Smith

For a roof pitch less than  $\frac{3}{12}$ , a solid membrane roof of some sort is needed. One long-term solution is a flat-lock soldered copper roof. This can be done using just a few hand tools<sup>1</sup>, but the time required can be greatly reduced with the proper sheet metal equipment.<sup>2</sup>

The basic component of this style roof is the roofing pan, which is a rectangle typically measuring 18" by 24," though I have seen old roofs with pans smaller or larger than this. The largest that I remember were 24" by 30." Multiple small pans are used, instead of fewer, larger ones, so that thermal expansion and contraction can be absorbed by each pan, instead of accumulating and concentrating in just a few areas, where it could tear the metal apart. If the roof area exceeds 30' in any direction, then an *expansion joint is needed*. I always have rolls of 18" 20 oz. cold rolled copper around for flashing purposes, so 18" x 24" stock is what I start with.

The pans will have  $\frac{3}{4}$ " folds around the perimeter, 2 turned up, and 2 turned down, as shown at right. Again, this could be less ( $\frac{1}{2}$ " or more (1")), but I find  $\frac{3}{4}$ " to be a nice width, in that there is some extra room for adjustment, when fitting them together without losing too much pan size. The corners have to be trimmed off first to allow the sides to be bent properly (Figure 2). At  $\frac{3}{4}$ ", scribe two lines in one corner, and draw a 45 degree line so that the intersection made by the two  $\frac{3}{4}$ " lines is cut off, leaving a  $\frac{3}{16}$ " wide corner. When the edges get folded, this will leave a  $\frac{3}{16}$ " wide crack which is called a butt (I'll pretend I don't hear that giggling!) This can vary, but if too thin, the pans won't fit easily together, and if too wide, there will be a big hole that needs to be filled with solder.

So the pans are cut to size, and the corners are cut off. Now they can be "pre-tinned,"<sup>3</sup> which means applying a stripe of solder around the perimeter of the pans, on both sides. Because we are making  $\frac{3}{4}$ " seams, the stripe will be twice that, or 1  $\frac{1}{2}$ ". Though pre-tinning is widely recommended, it isn't required. It does reduce the chances of having voids in the solder joints after the pans are assembled and soldered, but an experienced mechanic can apply all of the solder at one time, and be confident that the joints are good. Pre-tinning is a form of "idiot proofing," which, when you are a beginner, is a good thing!

Now, the edges can be folded (2 up, 2 down), at about a 130 degree angle. Your pans are ready for the roof.

The roof sheeting should be solid 1" boards, not plywood, and

covered with 30 lb. felt. Install rosin paper, so that the copper doesn't come into contact with the felt. This will keep the felt from melting into the solder joints, and provides a slippery

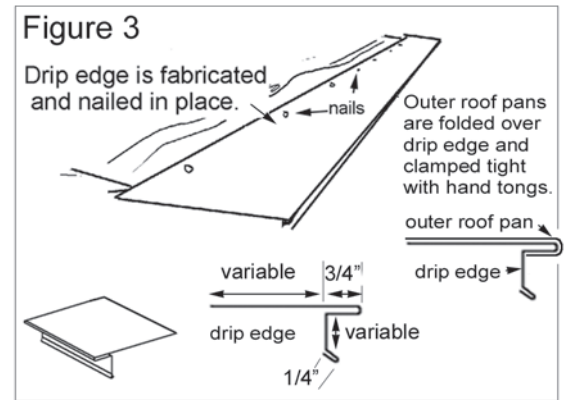
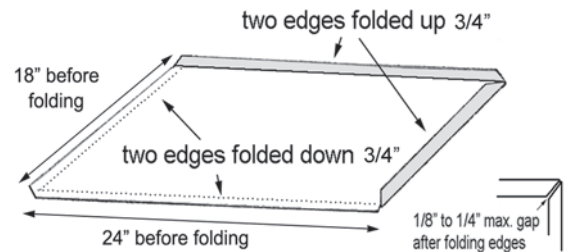
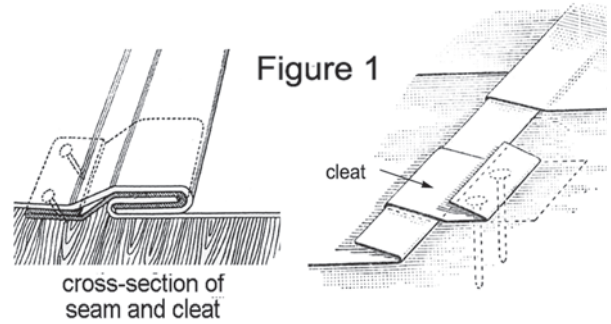
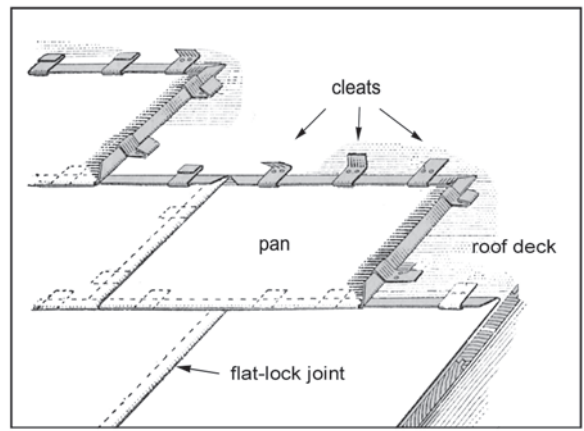
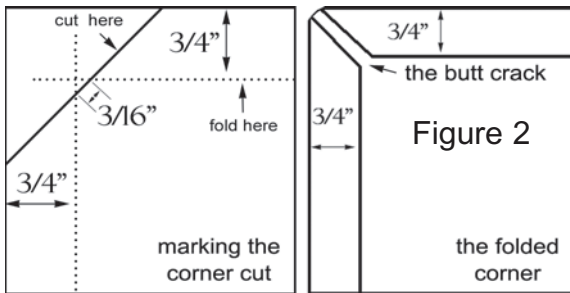

surface as the copper expands and contracts.

Install the drip edge (Figure 3). Snap a chalk line 22 $\frac{1}{2}$ " from the outside of the drip edge and begin installing the pans in the staggered pattern shown above using copper cleats measuring roughly 1  $\frac{1}{2}$ " by 3". Use the chalkline as a guide to keep everything straight, but don't worry if the pans aren't lining up perfectly. The cleats can be nailed with 1 or 2 nails (I've seen both recommended), and then folded over the nail. There can be two or three cleats on the long side.

The pans should ideally lay on the roof, so that water runs out of the joint, not into it. This isn't required however, since the joint will soon be filled with solder, and sometimes,

Photos this page and facing page by Joseph Jenkins

Continued On Next Page

certain details are more easily assembled and more easily soldered if the joint is "backwards."

Resist the temptation to assemble the pans as tightly as you can, because when the seams are pounded down flat, the pans will tighten against each other. Use a mallet to start the process of pounding down the seams and then a dead blow hammer to pound them *as flat as possible*. The flatter they are, the easier to solder. Don't assemble too far ahead before doing this. Most roofs are going to have more details than just edge pieces and standard pans. For some detailed explanations and drawings of some of the possible pieces that might need to be constructed (including the expansion joint mentioned above), you can look at the Copper Development Association's website. This is the address to the page on flat seam roofing — [http://www.copper.org/applications/architecture/arch\\_dhb/roofing/flat\\_seam\\_roofing.html](http://www.copper.org/applications/architecture/arch_dhb/roofing/flat_seam_roofing.html).

To prevent leaking, you should solder all of the seams that you assemble each day. It is not the purpose of this article to do a tutorial on soldering, but here are the basics. A heavy soldering iron should be used with a wedge shaped, or chisel tip. Stay Clean flux is the best that I have found for copper (thanks Chris Paulin!), although other suitable brands include Ruby Fluid and Johnson's Flux. The solder should be 50/50 tin/lead in either 1 lb. or ¼ lb. bars. Assuming the copper is relatively clean and bright, first brush or squirt on the liquid flux, hold the hot iron on top of and against the seam, then add additional solder when the metal gets hot enough to melt it, until the joint is filled. You might have to add additional flux. Move the iron slowly in the direction that you are soldering, not quickly back and forth.

I've seen that others recommend a practice called "stitching" that involves going back over the soldered joint and walking the point of the iron across the seam about every ¼" and adding more solder. It is usually explained that this will draw more solder into the joint. If this is drawing more solder into the joint, then you didn't do it correctly the first time. The only good reason to stitch a joint is for aesthetic reasons — if you like the look. Stitching adds a lot of time and doesn't improve the performance.

You should practice on some scrap pieces and cut them apart to see inside the joint. Do this until you have some confidence that everything is bonding well and there aren't any voids.

**Do not use a torch, whenever there is flammable material underneath the metal being soldered! This can start a fire.** The whole purpose of the iron, is to give you greater control of the heat being applied, so that just enough

heat to melt and draw the solder is used, and no more.

When the soldering is completed, the copper will be a mess from the whole process. To clean it up: brush down the whole roof with flux; then brush and rinse this off with soda water (1 lb. of baking soda stirred into a 5 gallon bucket of water); now, rinse the whole thing off with water.

Remember, practice makes perfect! 

<sup>1</sup>Tin snips, hand seamers, scribe, wooden mallet, dead-blow hammer, soldering iron; <sup>2</sup> Foot shear, brake, solder trough; <sup>3</sup> This can be done with a soldering iron, or with a solder trough. I have made a trough from scratch, using a stainless steel melting trough with some legs welded on and a propane burner underneath, protected by a windshield. While very effective (see photo at right), I'm told that it might be improved (and possibly safer) by fitting a regular furnace type burner to it. Since the design is still being worked out, I don't want to make any recommendations yet. Slateroofcentral.com has an electric one for sale (see below).



Barry Smith pre-tins copper pans in a pre-tinning trough.

## TOOLS FOR FLAT-LOCK COPPER WORK

**Tennsmith brake** — needed for folding the edges of the pans. Can be 24", 48", 6', 8' or 10' brake.

**Tennsmith foot shear** — great for cutting the pans out of 18" or 24" coil stock copper.

**16 or 20 ounce copper** — 18" or 24" rolls are already the correct width for cutting into 24"X18" pans.

**Soldering devices** — These should be "closed flame" soldering devices, such as the Swedish-made Sievert, the French-made Express, or the Johnson acetylene torch. Or use an electric soldering device such as the American Beauty 300 watt model. Or use hand irons and a Johnson bench furnace.

**Solder** — Use either 1/4 lb. 1/2 lb. or 1 lb 50:50 tin/lead bar solder.

**Hand tongs (seamers)** — We have a large selection of brands of this handy tool used for bending metal by hand.

**Electric soldering trough for pre-tinning** — by Wenesco

All of these tools are available at [SLATEROOFCENTRAL.COM](http://SLATEROOFCENTRAL.COM)  
PH: 814-786-9085



Member:  
Slate Roofing Contractors  
Association of North America

Fully Insured



Installation - Maintenance - Removal - Repair - Inspection

Barry Smith

**SLATE ROOF RESTORATION**

10323 Mitchell Road, Union City, PA 16438  
Ph: 814-438-2717 - Cell: 814-450-4446

[barrysmith@hotmail.com](mailto:barrysmith@hotmail.com)

# SLATERS CONVERGE

in western Pennsylvania  
for the 2007 Slate Roofing  
Contractors Association of  
North America Conference



THE WORKSHOPS: flat-lock copper, built-in-gutter expansion, rounded slate valleys...



## SRCA Current Members

November 2007

All State Roofing and Siding LLC,  
Alluvium Construction  
Alois Roofing LLC  
Balanced Builders, Inc.  
Beach Sheet Metal Company, Inc.  
Black Diamond Slate LLC.  
Blackmore and Buckner Roofing  
Coffey Contracting Co., Inc.  
Camara Slate Products, Inc.  
China Materials International  
CMR Construction and Roofing  
CUPA Natural Slate  
Bill Davis Roofing, LLC  
Dax's Roofing Workings  
Durable Slate Company  
Fania Specialty Roofing Group  
Gheen Brothers Construction, Inc.

Ross A. Gibson  
Gough SnoGuards  
Greenstone Slate Company  
GS Restoration Services  
Heritage Roofing, Inc.  
Ferrari-Adler, Scott  
Hayden-Lyons  
J. B. and Co. Roofing  
Joseph Jenkins, Inc.  
C.D. Kaller, Inc.  
Leeland's Slate Roof Repair  
Lowe Roofing and Restoration  
Mahan Slate Roofing Company  
Midland Engineering Company  
Miller-Thomas-Gyekis, Inc.  
Milligan Construction  
MJC Roofing  
Mountain State Slate Roofing  
Newmont Slate Co., Inc.

North American Slate and Stone  
North Country Slate  
Northeast Slate  
Old World Craftsmen, Inc.  
Paulin Slate and Copper  
Penn Big Bed Slate Company, Inc.  
Perlino Slate Roof Repair  
Preferred Roofing, Inc.  
Premier Roofing Specialists, Inc.  
Professional Home Inspectors Inst.  
Renaissance Roofing, Inc.  
The Roofing Company, Inc.  
Ruff Roofers, Inc.  
Salvo and Sons, Inc.  
Sam and Mary's Woodworks  
Scottie Ballantyne Roofing, Inc.  
Shaanxi Weststone Ind. and Trade Co.  
Slate Affair Inc.  
Slate International, Inc.

Slate Roof Repair Specialists, LLC  
Slateworks Roofing  
Smith Slate Roof Restoration  
Statewide Roofing  
Stevens Roofing Corp.  
The R. W. Stokes Company  
Tile Roof Specialists  
Tatko Stone Products, Inc.  
Technical Management, Inc.  
Tile Roofs, Inc.  
Triple M Contracting, Inc.  
Twelfth Century Slate Roofing Co.  
Vermont Recycled Slate and  
Roofing, Inc.  
The Vintage Slate Company, Inc.  
The Virginia Slate Company  
Wagner Roofing Company  
Zimmermans Slate Roofing  
Specialists, LLC,

**SLATE ROOFING CONTRACTORS** from around the United States, and a guest from Germany, converged on western Pennsylvania in June 8-10, 2007 for a three day weekend of workshops, meetings, presentations, food, music and camaraderie. Six concurrent workshops took place over the three day period, including 1) a flat-lock soldered copper workshop conducted by Barry Smith of Smith Slate Roof Restoration in Union City, PA (see page 6); 2) a rounded slate valley workshop conducted by Brent Ulisky of Joseph Jenkins, Inc., conference host (see Ulisky's article on page 10); 3) a slate siding workshop conducted by Liam Tower of Slate Affair, Inc., Enosburg Falls, VT (see article, page 14); 4) a soldering workshop conducted by Chris Paulin, Paulin Slate and Copper, Akron, Ohio (see Paulin's soldering article on page 26 and for more about Paulin, see Project Spotlight article, page 22) ; 5) a snow rail installation demonstration conducted by James Warden of Milligan Construction, Providence, RI (for more about snow rails see page 36; for more about Warden, see page 3); 6) a built-in gutter expansion joint workshop conducted by Rich Stainbrook, Heritage Roofing , Shady Grove, PA (for more about expansion joints in built-in gutters, see page 16).

Additional presentations included: Copper Clad Stainless Steel, Home Inspectors, Common Slate Roof Installation Mistakes, Thomas Massie's New Slate Roof Installation (see article, page 20). Live music was provided by the Fabulous Roof Rockers on Friday night and by the Slab Town Boys on Saturday night. Several kegs of beer were generously donated by Camara Slate Company of Fair Haven, VT.

Members who attended this conference included: Perlino Slate Roof Repair, Slateworks Roofing, Durable Slate Company, Stevens Roofing Corp., Dax Billcheck Roofing Contractors, Mahan Slate Roofing, Heritage Roofing Inc., Mountain State Slate Roofing, Smith Slate Roof Restoration, Slate Affair Inc., Milligan Construction, Paulin Slate and Copper, Bill Davis Roofing LLC, Joseph Jenkins, Inc. New members who joined at the conference included Martin Bungartz (supporting), Sam McMillen (supporting), Professional Home Inspecting Institute (supporting). There were also various non-member guests attending. For more photos of the conference, look at the online photo album at [slateroofers.org](http://slateroofers.org).

## ...snow rails, soldering, slate siding



## SRCA EVOLVING INTO NON-PROFIT TRADE ASSOCIATION, JANUARY 1, 2008

The Slate Roofing Contractors Association of North America, founded in March of 2005 as an Unincorporated Association in the state of Pennsylvania under the auspices of Joseph Jenkins, Inc., is transforming into an independent, non-profit trade association, not associated with any particular slate industry business, at the beginning of the year, 2008. The SRCA can best benefit the American slate roofing trades and industries by existing as a non-profit agency. An interim Board of Directors has been assembled. The SRCA's primary focus is on slate roof contracting and the skills and practices of those who install slate roofing materials.

Membership in the SRCA is open to slate roofing contractors (Slate Roofing Contractor membership), general roofing contractors (Roofing Contractor membership), others in the slate industry such as quarriers, marketers or consultants (Affiliate membership), and the general public (Supporting membership). More information can be found at [slateroofers.org](http://slateroofers.org) or by calling 814-786-9085, 9-5, M-F, eastern time. Your inquiries are always welcome!



PHILIP TERMAN, author of The Slate Roof Poem in the Slate Roof Bible, reads the poem at the conference ▼

▲ Several presentations, meetings and discussions were held at the conference



# ROUNDED SLATE VALLEYS

Brent Ulisky

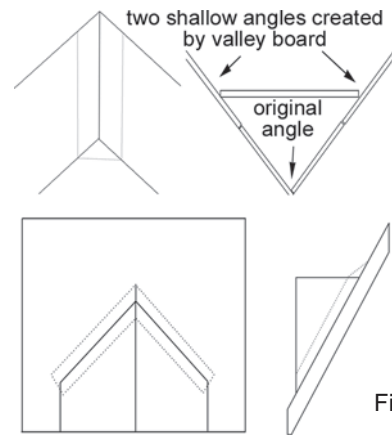
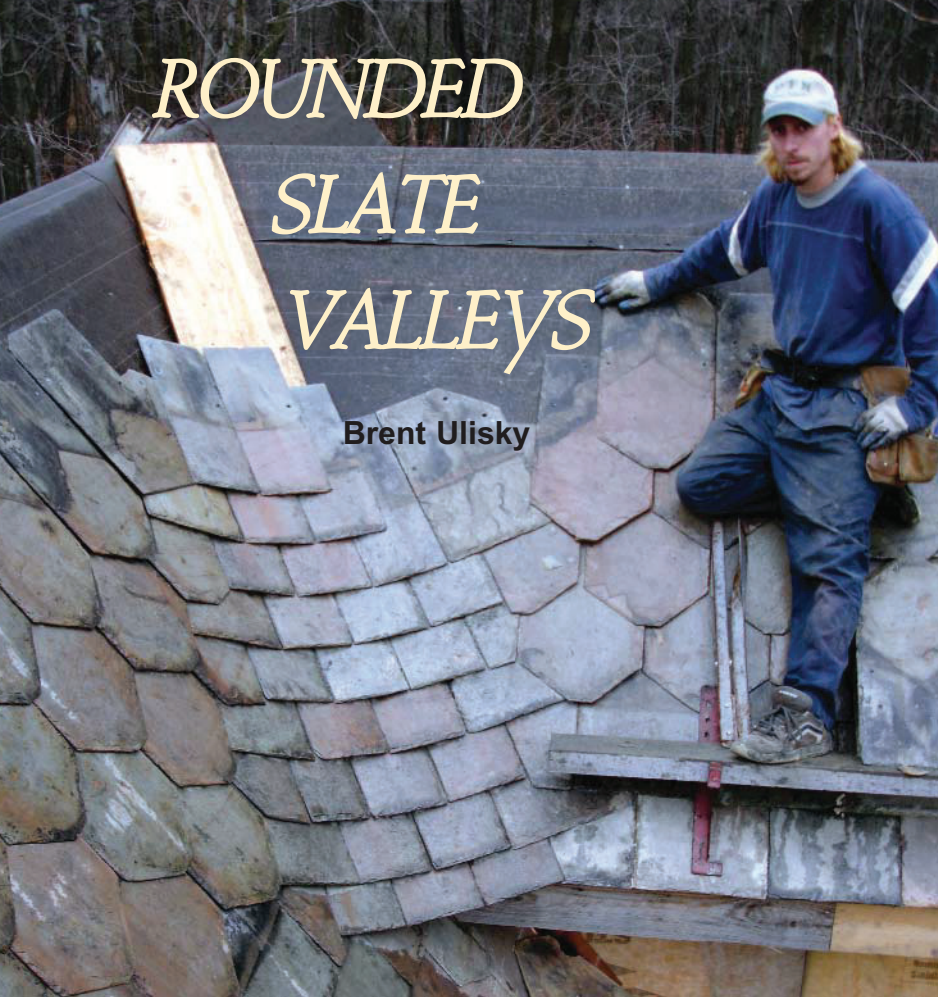

Figure 1

be covered by forming a piece of copper or cutting a board to fit.

The next step is to chalk vertical lines running the length of the valley board. The first line needs to be chalked down the center. The other two lines depend on the width of valley slates to be used. I found using slates six to eight inches wide works the best. For example, if you're using six inch wide valley slates, the other two lines need to be chalked parallel to the center line three inches out on both sides.

After the lines are chalked, the valley is ready to be slated. If you're slating a valley on a dormer that is part way up the roof you may need to adjust the dormer field slates so the bottom of the first valley slates meet up with the bottom of the main roof field slates. The valley slates should be longer than the field slates to get maximum head lap\* and the nail holes need to be punched higher than normal.

Next run the dormer starter slates up to the valley and install a starter slate on the valley board. [See Traditional Roofing #5 at [traditionalroofing.com](http://traditionalroofing.com) for an article on starter slates.] Continue by placing a valley slate (i.e. slate that lies in the valley) in the center of the valley board with the bottom edge flush with the bottom of the starter slate. Install two more valley slates, one on each side of the center slate. Some of the outer valley slates may need their top corners trimmed to help them

THE FIRST TIME I SAW A ROUNDED VALLEY I was in awe. The beauty of the slate appearing to bend around the valley was to me a work of art. Then I had the opportunity to see some rounded valleys being installed at the International Federation for the Roofing Trades World Championship for Young Roofers in Edinburgh, Scotland. Since then I have installed six rounded valleys, four on my own house. Here is what I have learned so far.

The rounded slate valley style shown at bottom, right, is the style described in this article. It typically requires a strip of valley flashing underneath each course of valley slates. There are many styles of rounded slate valleys, some of which are illustrated in the Slate Roof Bible. The rounded valleys shown in the photo above and below were installed by Ulisky on his own home with no valley flashing strips or even underlayment in order to test the watertightness of this system. This style utilizes two courses of valley slates for every course of field slates and therefore should not require valley flashing. The valleys have tested to be leakproof in rainy western Pennsylvania.

The first step to a rounded valley installation is installing a valley board. A valley board is 1 inch in thickness and from 9-12 inches wide and runs up the center of the valley. The purpose of this board is to convert one deep angle into two shallow angles. If the rounded valley is to be installed on a dormer, the boards must be cut to meet each other at the dormer top. This will cause the top of the boards to angle up the roof (Figure 1). After the valley board is installed, there will be a void under the valley, creating a hole at the bottom. This can

Continued On Next Page 



Brent Ulisky at the 2007 SRCA Conference

All photos this page and facing page by Joseph Jenkins

lie flat. It may also be necessary to use longer nails on the valley slates.

After that course of valley slates is installed, you can run the field slate up to them. Cut the field slates as needed to meet the valley slates. Install a strip of 16 or 20 ounce copper or terne-coated stainless steel step flashing before the next course of slates are nailed down. The copper should cover the top, unexposed portion of the valley slates,

extending the width of the valley slates, and extend up the valley slates the distance of the exposure measurement plus 4" (see Figure 2). The bottom edge of the copper strip will just be covered by the bottom edge of the overlying valley slates. No copper will be visible after the overlying slates are installed.

The next course of valley slates will need four slates. Start by placing a slate on each side of the center line. Then place one more slate on each side of these slates. Make sure the bottom outer corners of the valley slates meet up with the bottom of that course of field slates. Continue up the valley using these steps till you reach the top. At the top it will be necessary to cut the valley slates to meet one another causing them to sweep up the main roof. Use flashing as needed.

The slope of a slated valley should be no lower than (7:12). The steeper the slope the better. It is not recommended to slate a rounded valley over twenty feet long. 📐

Brent Ulisky is slate roof mechanic foreman at Joseph Jenkins, Inc.



Photo by Joseph Jenkins

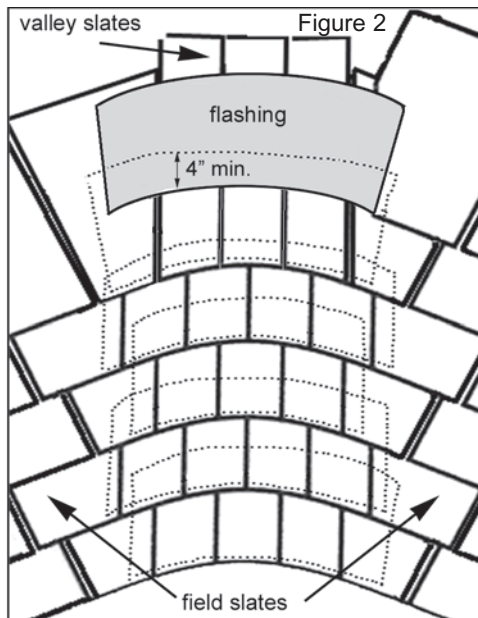

\* [Editor's Note: Traditionally, the valley slates were long enough to have a double headlap so that the head of the valley slate was overlapped by the second course above, as is normally done, but also by the third course above by an inch or two. (See the article on headlap in this issue for more information about overlap.) To calculate double headlap, triple the field slate exposure measurement, then add the 2nd headlap measurement. For example, if you're using an 18" long field slate, the exposure with a standard 3" headlap in the roof field would be 7.5". Therefore the valley slates would be 3 X 7.5" or 22.5" plus 1.5" headlap on the third course above, requiring a 24" long valley slate. Valley slates longer than 24" are often impractical, so the field slates must be limited in length to 18" or else flashing must be installed between each course. If flashing is used, the length of the valley slates is not critical.

## From our Historical Archives

The Manufacturer and Builder.

87

### Statistics of Slate Production in the United States.

From the advance bulletins issued by the Census Bureau, we are enabled to give the following statistical information respecting the production of slate in the United States. The work of collecting the data relating to this industry was done by Dr. William C. Day, under the direction of Dr. David T. Day. The more important of these facts and figures are given herewith:

**Production.**—The total value of all slate produced in the United States in 1889, as shown by the following table, is \$3,444,863. Of this amount, \$2,775,271 is the value of 828,990 squares of roofing slate, and \$669,592 is the value of slate for all other purposes besides roofing.

As compared with the statements of the tenth census report of 1880 on stone, the roofing slate product of 1889 is nearly twice as great in number of squares and in value. A consideration of the slate used for purposes other than roofing, appears to have been omitted from the tenth census report. The total value of all slate produced in 1889 is more than twice as great as that considered in the tenth census.

**Distribution of the Quarries.**—Twelve States at present produce slate. A line drawn on the map from Piscataquis county, Maine, to Polk county, Georgia, and approximately following the coast outline, passes through all the important slate-producing localities. According to amount and value of product, the most important States are, in the order named, Pennsylvania, Vermont, Maine, New York, Maryland and Virginia. In the remaining six States productive operations are of limited extent, and in the case of Arkansas, California and Utah of very recent date.

The twelve States referred to do not include all those in which merchantable slate is known to exist, since discoveries promising good results for the future have been made in a number of other States, among which may be specially mentioned Tennessee, where operations of production are beginning.

#### PRODUCTION BY STATES FOR THE YEAR 1889.

STATES.	Number of Quarries.	Number of Squares of Roofing Slates.	Total Value of all Slate Produced.
Arkansas.....	1	60	\$240
California.....	2	2,504	13,889
Georgia.....	4	3,050	15,330
Maine.....	4	43,500	214,000
Maryland.....	5	23,100	110,008
Michigan.....	1	3,000	15,000
New Jersey.....	5	2,700	10,925
New York.....	16	17,167	130,603
Pennsylvania.....	104	474,602	2,011,776
Utah.....	1	..	..
Vermont.....	60	235,850	838,013
Virginia.....	3	23,457	85,079
<b>Total.....</b>	<b>206</b>	<b>828,990</b>	<b>\$3,444,863</b>

# READERS WRITE



Thanks for the latest issue of "Traditional Roofing." I'm a geologist and love stone or rocks of any flavor. I especially enjoyed the article on senior slaters. I, too, am one. At 63, I tried my hand at it, building a truck port/covered patio with a slate roof with a copper ridge. I very much enjoyed doing it. G.L., Denver, CO

**VALLEY REPLACEMENT** — I am having repair work done on a slate roof that is about 59 years old. The problem is that the copper valley flashing, original to the house needs to be repaired. One roofer suggests replacing the copper with aluminum flashing, while the other roofer suggests applying a membrane to the existing flashing so as to not have to take up the delicate slate. One roofer says the slate is in good condition with perhaps 25 more years useful life in it. My question is — is it better to go with replacing the flashing or go with a membrane applied over the existing? Replacing the flashing and other incidental work (replacing lost shingles, painting a tin roof, and sealing roof peaks) comes to about \$4,450.00, while the membrane method and incidentals is set at \$2,000.00.

**TR** — Replace the flashing. Don't use membrane. If the roofer is recommending membrane, he doesn't know what he's doing. Valley replacement is routine work for an experienced slater. It should cost, roughly, about \$60/running foot to install 20 ounce copper.

**EARTHQUAKES** — We are re-roofing our home and would like to use slate for aesthetic, durability and fire resistant reasons. However, we are concerned about how it will hold up in the (inevitable) event of a medium to major scale earthquake. We are within a stone's throw of a fault line in the hills north of Berkely, CA. Has there been any testing of slate under the stress and impact of seismic events? I am concerned that the shock of the event would cause the slates to shatter at the nailing points or shatter on impact with each other, sending slates raining down in a lethal (or at very least expensive) wave of debris.

**TR** — A tornado ripped the roof off a local garage/apartment and dropped it on the ground nearby. The slates remained intact and we removed them and recycled them onto the new garage after it was built. There is a photo of it in the Slate Roof Bible, 2nd edition, page 206. I was on another slate roof on an old two-story farmhouse when an earthquake hit nearby (a very rare event here in Pennsylvania). I was at the epicenter sitting on the ridge of the roof when there was a loud rumbling and the house started to shake like rubber. Just as I was looking for a place on the lawn to leap (thinking the house was about to collapse), it passed. There was no damage to the slate roof. Of course, this was only about a 4 on the Richter scale. Both of these situations indicate that a slate roof can be flexible under duress.

**GALVANIZED NAILS AND COPPER GUTTERS** — My contractor used galvanized nails to secure the copper gutter fascia hangers. I complained to him that this would result in galvanic corrosion (if it weren't for your book, I wouldn't know about that). He stated that since he used galvanized nails with a spiral shaft, they cannot be pulled out. I am now stuck with either (a) living with the galvanized nails that will corrode over time, or (b) have the contractor cut every nail head off and possibly damage the copper gutter in the process. He would then replace the nails with stainless steel screws. If complete destruction of the galvanized nails through galvanic corrosion will take a long time to occur (50+ years), I might be willing to live with it. What should I do?

**TR** — The contractor should have used stainless or brass screws. The galvanized nails will last quite some time, however, especially if they don't get wet. I don't know that they'll last 50 years, however.

**DIY VS ROOFERS** — In the "Readers Writes" (TR5) you are questioned on 'cretin and ex convict' descriptions. "Liars...inept,...drunks" is further noted as part of your description of

Continued On Page 25

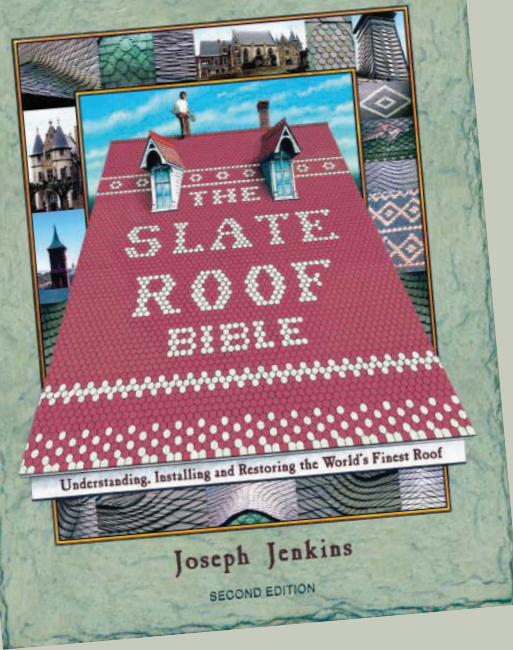

## THE SLATE ROOF BIBLE

now in its 3rd edition (2016)  
(2nd edition shown above)  
by Joseph Jenkins

Order discounted at Amazon.com.

**WRITERS DIGEST:** "The author's obvious love for the subject comes through in all aspects of the book, from the text's dense information to the scores of wonderful photos throughout the book. The craftsmanship of the book itself is very professional. All in all, a very good read."

**MIDWEST BOOK REVIEW:** "...a not-to-be-missed specialized reference. Packed with over three hundred color photos, the Slate Roof Bible is the core reference of the slate roof industry, covering everything to know about installing, restoring and maintaining a slate roof. Highly recommended."

**WRITERS NOTES BOOK AWARDS:** "The Slate Roof Bible was the first book to grab our attention and hold it. It's more than just a handbook. It's a great read and a thorough reference volume in one, a rare combination of fact and experience that creates learning and appreciation — a reference book that becomes literature."

**FINE HOMEBUILDING:** "The Slate Roof Bible is a fine book, filled with fascinating information about slate: its history, the industry, and the way to work with it properly."

**DOYLESTOWN INTELLIGENCER RECORD:** "This book, potentially tedious reading, is instead a delight. Full of history, lore, and useful advice, Jenkins has written a fascinating book, spiced it with humor and warmed it with his own passion for the subject."

**ROOF CONSULTANTS INSTITUTE INTERFACE JOURNAL:** "Rarely does one read a book expressing such personal enthusiasm and technical knowledge as that written by Mr. Jenkins. Jenkins has provided the roofing community with a definitive, single-source manual for slate roofing."

**NOTRE DAME SEMINARY  
NEW ORLEANS, LOUISIANA**

HISTORICALLY ACCURATE  
FABRICATION AND INSTALLATION  
OF A 22 FOOT TALL COPPER  
CUPOLA COMPLETE WITH 32  
SPUN COPPER BANNISTERS,  
14" RADIUS COPPER SPHERES,  
A 60" BRASS CROSS, AND 8  
PRESSED COPPER CAPITALS WITH  
INTRICATE LEAF DETAILING.  
WE ALSO DUPLICATED 800 FOOT  
OF ORNATE COPPER HIP & RIDGE  
WITH 7 COPPER FINIALS THAT ARE  
OVER 10 FOOT IN HEIGHT.

OUR METAL CAPABILITIES INCLUDE:

- BRAKE METAL
- ROLL FORMING
- ENGLISH WHEEL FORMING
- HAND FORGING
- PRESSED/STAMPED METAL
- SPINNINGS

WE CAN DUPLICATE FROM YOUR  
ORIGINALS OR CUSTOM DESIGNS.

- GALVANIZED
- COPPER
- STAINLESS STEEL
- TSCII

**VICTORIAN SHEET METAL**

**TOLL FREE: 1-866-202-4778**

[WWW.VICTORIANSHEETMETAL.COM](http://WWW.VICTORIANSHEETMETAL.COM)

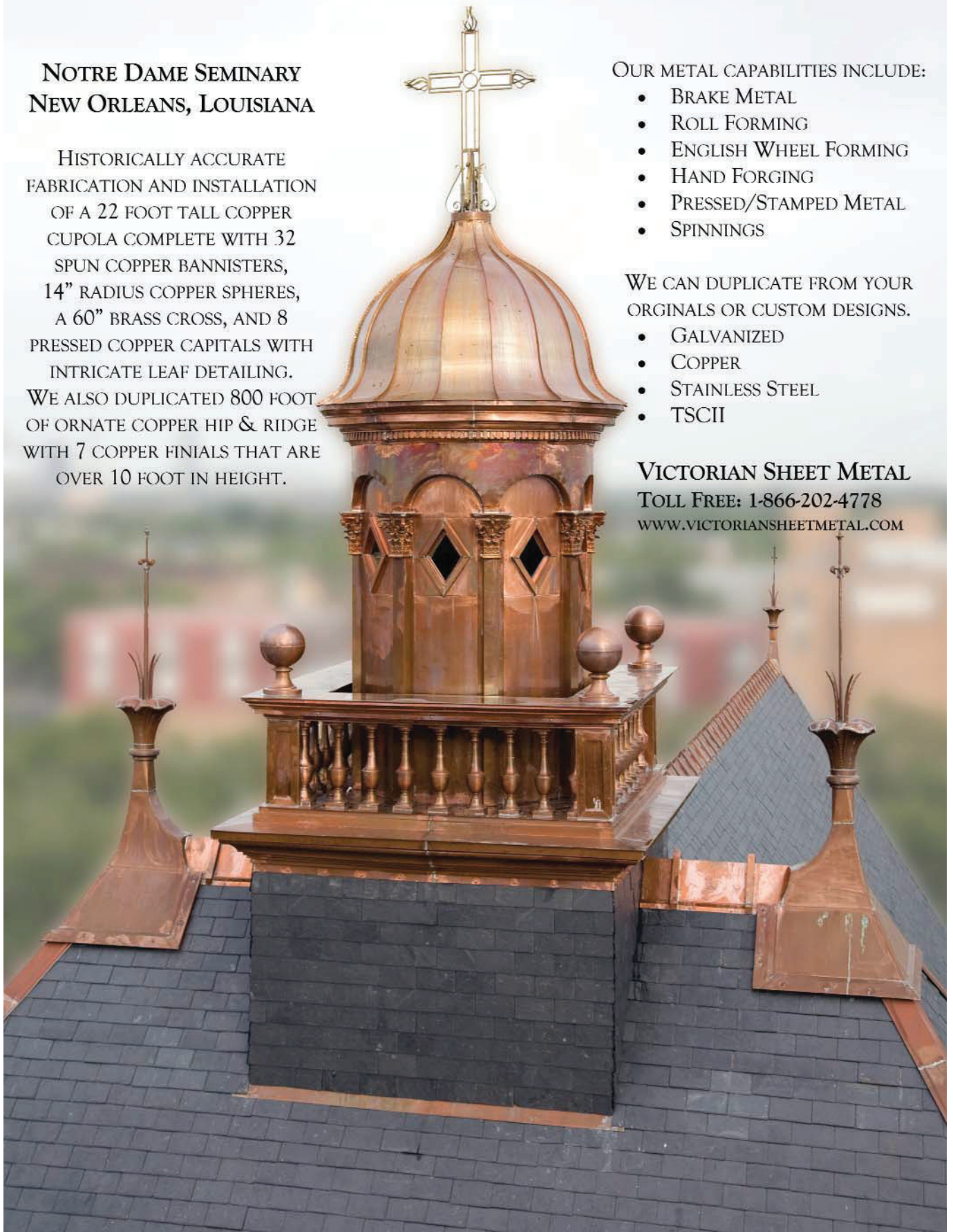

# The Art of Slate Siding

Liam Tower

**WATCH WHERE YOU'RE GOING** or you may run into two geese. At first glance, you may look away, but then you look again. You are seeing an illusion of roof and side walls running into each other. Look again — it

is a 3-D mural combining various slate colors and patterns. This particular slated wall is about 12 feet wide and 8 feet tall with a vanishing point perspective. Most people who have seen it in person call it a work of art. I like to think of it that way, too. Getting involved in work like this will give you a chance to become skilled in cutting and punching very small pieces of slate with a slate anvil. It is where a slate roofer can express his roofing and artistic skills in a fun and creative way.



▲ In Progress  
Completed ►



I was inspired to do the goose mural from pictures of slate art in the Slate Roof Bible and other European web sites with wild roof coverings and slate art. Before starting this project, I slated two houses in Vermont. This helped me to develop designs and ideas for other constructions with slate. When I get started with the job, I begin with a three hour trip to southern Vermont to the slate quarries. I usually go to Taran Brothers Inc. for my slate. I make this ride so I can personally hand select the used or new slate. When using used slate it is best to see it in person because of the many ways patina is layered in the slate and how the slate has aged. Different air conditions and pollutants also affect the process. All the slate siding I have done has used slate that has been on a roof for 70 to 100 years before installing it on the building I am doing. This is a great siding alternative to your more typical sidings. Used slate is a great "green" building material, too.

At Slate Affair Inc., we look forward to artistic and creative jobs. If it's not challenging, it's not as much fun to do! We have worked on jobs from San Jose, CA, to

Oyster Bay, Long Island, NY. Our latest job is a mix of slate, slate siding, slate chimney caps, copper details, block copper, and copper standing seam with a Dawn Solar Thermal hot water system. It is a meticulous and personalized project that will take eighteen or more months to complete. With most of these projects, I am in direct contact with my clients, making it easy to get their input. This is the key to creating a great roof or slate siding project. Look for more from the world of Slate Affair Inc. 

*Liam Tower is the owner of Slate Affair Inc., specializing in 100 Year Roofing.*

Slate Affair Inc.,  
P.O. Box 677,  
Enosburg Falls, VT  
05450, Ph: 802-  
848-7679; Fax: 802-848-7679;  
Cell: 802-793-8349; [liamtower@slateaffair.com](mailto:liamtower@slateaffair.com)

All photos this page by Liam Tower except the photo immediately above, which was taken by Joe Jenkins.

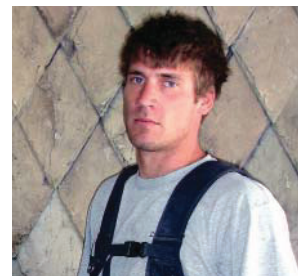

# SLATE SIDING FROM SPAIN AND GERMANY

The top two photos on the right are from Spain.

The other photos are from Germany.

Spain photos by Joseph Jenkins  
German photos by Jorn Witchert



# EXPANSION JOINTS

## IN BUILT-IN GUTTERS

Joseph Jenkins

Once upon a time, everyone's eyes glossed over with boredom when expansion joints were mentioned. But the lack of knowledge about expansion joints became a common reason built-in gutters (often called "box gutters") failed. As a slate roof consultant, I have the dubious pleasure of examining many failed box gutter installations, almost all of which show broken, leaking solder joints, and, guess what — no expansion joints! If you have to install, replace or repair a built-in gutter, you better expand your expansion joint knowledge.

Let's start with SMACNA. The Sheet Metal and Air Conditioning Contractors National Association emphasizes the importance of expansion joints, which, in their words, are "essential in all gutter installations." When no allowances for expansion are incorporated into a metal gutter design, the stress and strain of expansion and contraction will work on the weakest parts of the system, which happen to be the solder joints — eventually breaking them. On older box gutters the solder joints are often sealed with mastic, indicating leakage. If you look around, you will also notice that there are no expansion joints to be seen. Following SMACNA guidelines, a 20 ounce copper built-in gutter with a 12" bottom dimension should have a maximum distance to a fixed point, such as a downspout, ranging from 17' to 20', then there would be an expansion joint. The spacing of the expansion joints depends on the size of the gutter and thickness of the metal, but a general rule is that an expansion joint should be included about every thirty feet.

Most new box gutters these days are made of either copper or stainless steel, although many old box gutters were made of terne-coated steel. These metals expand and contract with temperature changes and this must be accounted for when designing gutter systems (Figure 1). If not, something will break from strain, which could happen sooner rather than later. Although the solder joints are most likely to crack and leak, the metal itself can split due to expansion and contraction. This is why box gutters are not nailed into place — they're set into place, clamped over an outside drip edge (see flat-lock article, page 6) and cleated to the roof deck (Figure 3). This allows the metal to move without undue stress. The expansion joints add an additional, necessary measure of protection.

What exactly is an expansion joint? Simply stated, a box gutter is terminated with an end cap as if the gutter has ended. Then, a space of an inch or two separates that section of gutter from the next, which begins with another end cap. The space between the pair of end caps is covered with a clamped cap to prevent water entry and to allow the separate sections of gutter to move back and forth with temperature changes (Figure 4). Because an expansion joint consists of two terminations in the gutter system, it creates a dam in the system, preventing the flow of water across the joint. An expansion joint, therefore, should be located at a high point in the gutter, as water will then flow away from the expansion joint rather than try to flow through it. When a high point is not available, a drain outlet must be included or added to the gutter system on the uphill side of the expansion joint.

Incidentally, when soldering a built-in gutter, care must be taken to not use an open-flame torch. Open flame torches are notorious for igniting buildings underneath the metal flashing because of the extreme heat of the open flame. Instead, only closed flame or electric soldering torches should be used. Furthermore, if the joints on the gutter system are lap joints (where the metal simply overlaps), the overlap should be approximately 1.5" and riveted every inch when using 1/8" pop rivets, and every 1.5" when using 3/16" pop rivets (Figure 2). The rivets should be made of a metal that is compatible with the metal of the gutter lining. For a copper gutter, copper rivets with brass mandrels should be used. Copper rivets with steel mandrels should be avoided. Check your rivets with a magnet — if they stick, they're no good! On the other hand, if the joints on the gutter are lock joints (joints folded together), no rivets are needed (see related articles on pages 6 and 26).

If a built-in gutter system happens to be installed without expansion joints, the joints *can* be added later, although it's quite a bit more difficult than adding them at the time of installation. To add a retrofit expansion joint, a section of the gutter lining approximately 1.5" wide must be removed. This can be done using a metal blade on a high-speed grinding tool, for example. Once the section is removed, the gutter is in separate segments. Each segment is then fitted with a custom fabricated "end-cap" termination. The two terminations are then soldered into place and a top cap is fitted over them. A drop outlet may then need to be added.

Remember, when installing built-in gutters, don't nail the gutter sections to the roof — use a clamping and cleating system. Also, either a) lock-seam or b) lap seam and rivet the joints, then fully sweat them with solder, using a safe soldering device. Include an appropriate number of expansion joints as recommended by SMACNA, and everyone will live happily ever after. ☐

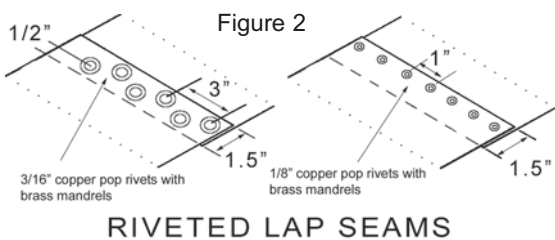
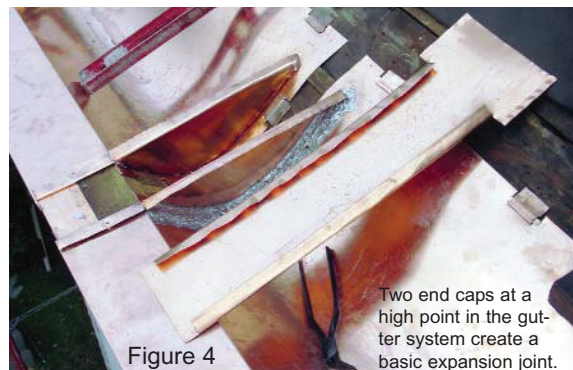
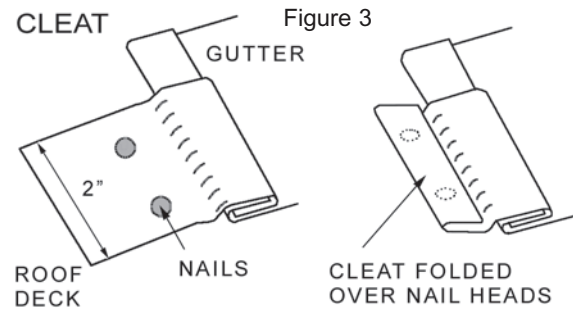
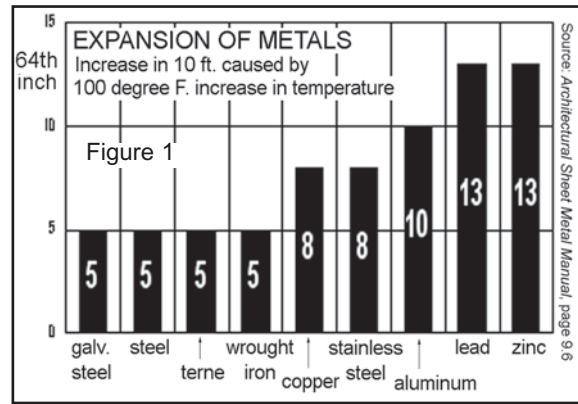

RIVETED LAP SEAMS

Source: Architectural Sheet Metal Manual, page 9-6

Photos by Joe Jenkins



# Fine Vermont Slate... Greenstone Service

When **Rhodes College** decided to build a new library at the center of campus, they chose **Greenstone Vermont Roofing Slate** for its beauty and longevity. They also wanted their new roof to be visually consistent with the roofs on buildings close by. We provided a blend of colors plus a variety of slate thicknesses to create a roof that would meet the aesthetic requirements of the architects and the college.

**Whether for a public building or a fine residence, Greenstone slate offers many benefits: in value, appearance—even environmental benefits and solar energy options.**

**Greenstone Slate** is your resource for the roof of a lifetime—in fact our slate comes with a **100 Year Warranty\*** You'll also find that we have the dedication to quality, professional service and customer assistance that matches the roofing slate we manufacture. We are ready to help find a solution that will fit your project in textures and colors, and inform you about lightweight installations and integrated solar options.

**GREENSTONE SLATE®**  
Vermont Architectural Roofing Slate

800 619 4333 • [greenstoneslate.com](http://greenstoneslate.com)

Barret Library  
Rhodes College  
Memphis,  
Tennessee



Ask us about color options and mixes. Slate roofs are always unique!

\*see warranty statement for complete details



## CROCKER ARCHITECTURAL SHEET METAL CO., INC.

*"The Crocker Team"*

has been a leader in bringing the benefits of historical restoration, specialty fabrication, and precision installation to building owners all over New England.

Their experience ranges from the smallest copper gutter installation to a 2.2 million dollar copper & slate project.



Private Residence  
Weston, MA



University of New Hampshire  
Thompson Hall

For more information,  
visit us at:  
[www.crockerarchitectural.com](http://www.crockerarchitectural.com)

129 Southbridge Road, North Oxford, MA 01537 Ph: 508.987.9900 Fx:508.987.9902



North America

Slate & Stone

314.698.6706

SUPERIOR SERVICE • FAST DELIVERY • IMP





EXCELLENT QUALITY • AFFORDABLE PRICES

There are rock solid reasons to choose North America Slate & Stone (NASS) Vermont roofing slate for your building products. Quality, beauty and durability are among the most important.

Vermont slate gives the dimension that elevates the eye appeal to awe inspiring. Highly durable, roofing slate can handle the test of time as well as the forces of nature. From our semi weathering to our unfading colors...NASS can make your creation and the impression it makes, a lasting one.

Our staff has hands on experience dealing with slate roofing and we are here to assist you with any questions you might have. We are members of the National Slate Association and all of our slate is rated S1 Grade per ASTM standards.

NASS, was founded with the vision of providing customers with service that is second to none in lead times, accuracy of promises, knowledge of product installations, product trends, and competitive pricing.

Call for more information and a free brochure. 

314.698.6706

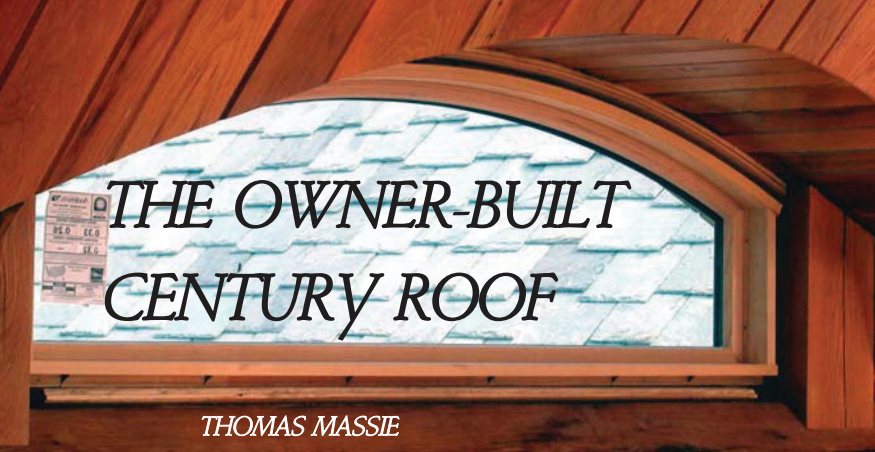

## THE OWNER-BUILT CENTURY ROOF

THOMAS MASSIE

WHEN MY WIFE AND I SET OUT TO BUILD A HOUSE three years ago, our goal was to build a structure that could last hundreds of years. After spending two years logging our own storm-damaged trees, sawing timbers on our portable saw mill, notching beams with chisels, erecting our timber frame, and quarrying our own sandstone, there was little doubt in our minds that slate was the only roofing material that could provide the honesty, beauty, and longevity we sought for our home. But because no one within two hours of our house site was familiar with slate roofs, it looked as though we might have to settle for a more conventional roof.

In the course of seeking a contractor, I stumbled across "The Slate Roof Bible." What my wife and I read there not only made us want a slate roof more than ever, but also convinced us that if we were willing to expend tremendous effort and pay attention to details, we could do it ourselves. Farmers without calculators slated roofs over a century ago and evidence of their work still stands (as with timberframing!). With lots of patience, surely we could do this too.

We were at first enamored with Buckingham slate for its legendary durability, but we found it difficult and expensive to acquire the genuine article. So instead we chose unfading grey and unfading green slate from Camara Slate in Vermont. We reasoned that by ordering a thicker slate (1/4" to 3/8") from a reputable quarry in Vermont, we could have our cake and eat it too... beautiful color and texture, with a service life also possibly measured in centuries, not decades.

When I ordered the slate (45 square without ever nailing or cutting a slate in my life), I figured that staggered butts and random width slates would be the best way to hide my inexperience in slating. But my wife had her heart set on a regular hexagonal pattern. To humor her, I first slated our outhouse in this pattern. It looked fine, but it took me 20 hours to do just over 1/2 square! If she was previously unconvinced to let me do a random style, I had surely convinced her at that point. The outhouse also helped me make another call... uncertain as to whether I should use felt underlayment or not, I slated the outhouse without it. Soon thereafter, I waited inside the outhouse during a driving rainstorm watching for leaks. Not a single drip. That settled it, no felt paper!

With a full 20 hours of slating under my belt, I enlisted the help of two in-laws (my wife's brothers) and one anonymous outlaw. Their previous slate experience consisted only of ripping off slate and putting down asphalt shingles, but they were all good carpenters, had stuck with us through the timberframing, and were eager to learn with me.

For sheeting, we used 1" thick by 3.5" wide boards cut from the same logs that comprise the oak timbers in our

house. Sawing, ripping, and planing all of these boards (most of them already well seasoned!) was an arduous task, so I decided to skip-sheet the roof instead of decking it solid. This required a lot of head scratching, because the spacing of the skip sheeting was dictated by the headlap (3") and exposure (7.5") of the slates that were going to be nailed into them. I had so many aborted chalk lines that I had to switch chalk colors three times. Just how did they do it without calculators?! Another downside of skip sheeting for me was that it made regular length slatehooks useless (and the application of underlayment would be troublesome... if you're into underlayment). However, skip sheeting had one big advantage that outweighed the others... it transformed my roof into a giant chicken ladder. In fact, we quickly adopted a method of nailing slates beside us (rather than above us), and that meant we never once had to use a roof jack. Of course, we still used safety lines.

Driving copper nails into seasoned oak was like trying to push a string up hill, so we used stainless nails to attach the slates. Humidity and higher-than-average fall-out from coal fired power plants take their toll on copper here in the Ohio Valley, so we also used stainless steel flashing for the closed valleys. Bending the 18 and 22 gauge stainless was simply not possible on a standard aluminum roofing brake, so I borrowed an industrial brake at a local race car fabrication shop. For on-site bends, we improvised with a bulldozer and sledge hammer. Driving a nail through 18 gauge stainless is no mean task either. At complicated intersections, such as the cricket behind the tower, I found it easier to weld 18 gauge stainless than to solder it. For the hidden flashing beneath the mitered hip slates, I restored sanity to the job site by finding a local source of easily worked 30 gauge terne coated stainless. On the ridges, I used interlocking copper pieces from Paradigm Shingle. They're meant to be used on copper shingle roofs, but I found that they work fine on slate, and the greatest benefit is that there are no exposed nail heads.

For several weeks, the eyebrow dormer (my wife spec'd it and wouldn't let me beg out!) was the bane of my existence. Slating it was not nearly so difficult as

Continued On Next Page 





All photos this article by Thomas Massie.

CENTURY ROOF (Continued From Previous Page)

building the wooden structure beneath it. I began by asking my wife to buy a window and I nailed it on the roof. Then I projected the arch of the window horizontally back to the roof sheathing and cut a hole in the interior tongue and groove ceiling. Further up on the roof deck, I drew an upside-down parabola whose legs intersected the legs of the window arch. I then bent some 1/2" green oak boards between the parabola and the top of the window to get an approximate ski-slope shape. These few boards helped me define the shape of the bulkheads (miniature eyebrow shapes that gradually decreased in size) that I then fabricated on the roof to support the rest of the oak boards that made up the dormer surface.

The slates that cover the eyebrow dormer are 8" wide with a few 7" thrown in to keep everything running correctly. The top corners are dog-eared so they will lay flat. Rather than cut the butts of the slates on an angle, I left them alone, which produced a staggered look that matched the rest of the roof. Between each course of slate on the eyebrow, I interlaced strips of terne coated stainless flashing (and 16 oz. copper when I ran out of TCS). A cynic might say that the eyebrow is essentially a stainless roof, with slate to disguise it. Whatever it is, it doesn't leak!

With the exception of the porches, which are not yet built, the roof has been finished for almost a year. The 45 squares of slate cost about \$20,000 and the nails, tools, flashing and ridges were approximately another \$5,000. I would estimate the labor, including nailing on the oak sheathing, to be about 200 man-days spread out over roughly 6 months (we didn't roof every day). If I could have done one thing differently, I think I would have included an attic, instead of cathedral ceilings, underneath my slate roof. I have 2 inches of air between the slates and the aluminum-faced Poly-Iso insulation (R-50), so the roof performs spectacularly, but if a leak ever occurs, it would be hard to track down. No worries though... I am both proud and relieved to report that the roof has not admitted a single drop of water! 🏠

The author (36) and his wife (34) graduated with engineering degrees from M.I.T. and started a computer peripherals/software company in New England. They left the high tech world to raise their four children on a family cattle farm in Kentucky. The self-sufficient home they are building (<http://massiehouse.blogspot.com>) is solar powered and "off-grid." Their plan is "to farm until the money runs out." They hope to finish their house before that happens.



# PROJECT SPOTLIGHT

Case Western Reserve University  
Alumni House , Cleveland, Ohio

## THE PAULIN SLATE & COPPER CO. Akron, Ohio

MUCH OF THE APPEAL OF SLATE ROOFS is their phenomenal longevity, with over 150 years of useful service life already proven in the United States. Yet, when a roof can last that long or longer, it can create a unique problem for itself — a need for trained and experienced slate roof mechanics who can repair or restore the roof when the time comes. In the slate industry today, any skilled slate mechanic is appreciated because it's a tough trade to be in, with a high degree of difficulty in the work itself, not to mention the workplace danger and the adverse working conditions. Slate roof restoration is a specialty trade that general roofers know little about, so when an historic building such as a church, courthouse, residence or a university Alumni House needs a complete slate roof renovation, where does the property manager begin?

The place to start is with a competent slate roof survey and evaluation by an experienced, professional slate roofing consultant who has no vested interest in the contracting job. Such an impartial and objective consultant will fairly evaluate the roof and determine what needs to be done and then provide important information about whether the roof should be repaired, restored or replaced altogether. In any case, once the correct approach has been determined, a competent slate roofing contractor must be found.

The Paulin Slate & Copper Company of Akron, Ohio and the Case Western Reserve University Alumni House in Cleveland are perfect examples of this scenario. Case Western Reserve University purchased the 1911 house in 1953, then decided, in 2007, that it would make a perfect Alumni House if it were completely renovated, inside and out. This meant that the slate roof needed a good going-over — many of the flashings needed replaced and some of the roof needed reslated. Joe Jenkins, of Joseph Jenkins, Inc, slate roof consultant, provided the roof evaluation, recommending that the Slate Roofing Contractor's Association contractor list be reviewed for a potential restoration contractor. Luckily, The Paulin Slate & Copper Company was on the list and the company had already established itself with a good reputation for slate and copper work in the Cleveland area. Chris Paulin had founded The Paulin Slate & Copper Company in 2001, choosing to leave the relatively sedentary architectural field to instead tackle the difficult, hands-on trade of slate roofing. With the help of his brothers, Mike and Anthony, (shown below with crew member Rick Miller) his company has quickly emerged as one of the foremost slate roofing professional services in northern Ohio.

The Paulin Slate & Copper Company completely reslated one section of the Alumni House using new slate from Camara Slate Products in Vermont in order to gain enough original Vermont weathering "sea green" 11"X22" slates needed to repair and restore the remainder of the roof (see photos below). The original slates had weathered to a dark brown and were difficult to match with other salvaged slates, as shown in the "before" photo, below. Paulin also replaced decking & ridge framing, valleys, aprons, step-flashings, ridges, vent pipe flashings, chimney flashings, copper spouting, bay window flashing and ledge flashings (see photos of ledges and bay window on page 26). The Paulin Slate & Copper Company can be contacted at 627 West Market, No. 8, Akron, Ohio 44303; tel: 330-242-1574; e-mail: [chris@paulinslate.com](mailto:chris@paulinslate.com), or on the web at [www.paulinslate.com](http://www.paulinslate.com).



[See Chris Paulin's Soldering article on page 26.]

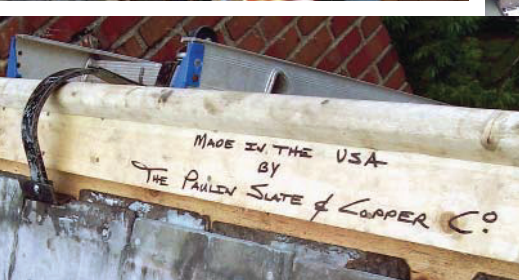
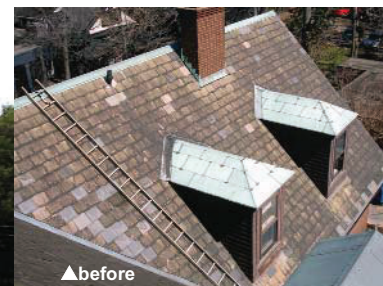

# Nothing Matches the Beauty and Longevity of Vermont Slate

**Vermont slate** is well known to be the hardest and most durable in the world. And Vermont's slate is available in a unique variety of colors found no where else. Our durable ASTM grade S-1 slate means durability and structural strength for a lifetime.

At **Camara Slate** we pride ourselves on the quality and service behind the slates we manufacture. From advice on color, size and thickness choices, to our competitive pricing, we will always strive to give you the best possible value. And all Camara product shipped will be

delivered to you with a guarantee of less than 2% breakage in transit. Also available: flooring, flagstone and pavers, and countertops. Please visit [camaraslate.com](http://camaraslate.com) for comprehensive information about our products!

#### Look to Camara Slate for:

- All Vermont slate colors and sizes
- Close to zero breakage in shipping
- Competitive pricing
- Straight forward industry information

#### Also providing:

- Slate flooring
- Countertops
- Flagstone
- Structural slate



Semi-Weathering  
Vermont Gray



Unfading  
Gray

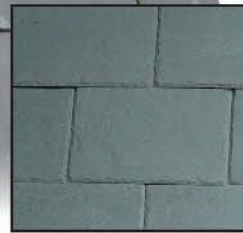

Semi-Weathering  
Sea-Green



Unfading  
Green



Mottled Green/Purple



Mottled Gray/Black



Royal Purple



Unfading Black



Semi-Weathering  
Vermont Black



Vermont Black



**CAMARA SLATE  
PRODUCTS**

Quarriers and Fabricators of Natural Vermont Slate Products

P.O. Box 8, Rt. 22A • Fair Haven, VT 05743 • Phone 802-265-3200 • Fax 802-265-2211  
[camaraslate.com](http://camaraslate.com) • [info@camaraslate.com](mailto:info@camaraslate.com)



# BLACK DIAMOND SLATE™

Call Toll Free (877) 229-9277



## Domestic and Imported Slate

Black Diamond Slate can provide slate for new construction or match your existing roof.

### Colors Available

Dover Black  
 Black Diamond  
 Cambridge Black  
 Winchester Black  
 Augusta Green  
 Georgetown Gray  
 Semi-Weathering Gray/Green

Vermont Black  
 Sea Island Gray/Green  
 Sea Island Purple  
 Vermont Unfading Green  
 Vermont Gray  
 Mottled Purple  
 Variegated Purple

All of our slate roofing products meet and exceed the S1 Grade Standard. We offer a full line of roofing slates from the United States, Spain, China and Brazil and have a full range of colors in new and reclaimed slate.

To receive a quote contact us at (877) 229-9277

Or visit us on the web at [www.blackdiamondslate.com](http://www.blackdiamondslate.com)

Diamond Building Products, LLC, P.O. Box 30957, Savannah, GA 31410

## TRIPLE M CONTRACTING, INC.



*One of New England's premiere roofing contractors serving the greater Boston area for over 20 years.*

148 Treble Cove Road, North Billerica, MA 01862-2212

Contact: Kevin Menenzes

Ph: 978-671-9523; Fax: 978-667-5873

[triplemcontracting.com](http://triplemcontracting.com) ❖ [kevin@triplemcontracting.com](mailto:kevin@triplemcontracting.com)



## Ross A. Gibson

ADVICE FROM EXPERIENCE



- \* Cost Estimates
- \* Project Manager
- \* Consultation Services
- \* Old Building Specialist
- \* Expert Witness Testimony
- \* Certified Building Inspector

- ◆ Semi-Retired Restoration Contractor
- ◆ 40 Years of Historic Preservation
- ◆ 3<sup>rd</sup> Generation Master Carpenter
- ◆ Avid Antique Tool Collector

[www.ROSSAGIBSON.com](http://www.ROSSAGIBSON.com)

1794 TURKEY POINT ROAD \* NORTH EAST, MD 21901  
410-287-3582

*those in the roofing trade. In your rebuttal, which falls far short of an apology, you go on about how "...when any Tom Dick or Harry can pick up a hammer and call himself a roofer "...it gets (your) hackles up." In perfect contradiction you, in the same magazine, glorify a "Tom Dick or Harry" do it yourselfer who purchased your "Slate Book Bible." Something's not right.*

**TR** — The difference between the lay-person and the ex-con roofing contractor is that the lay-person may actually educate himself before undertaking a slate roof installation, unlike some roofing contractors, many of whom already "know it all" and proceed to screw up the slate roofs they install. It's easy to insert "slate roofs" into Google, hit "I'm feeling lucky," and find all kinds of information about slate roof installation. It's not a matter of whether one is a roofer or not, it's a matter of whether one is informed and determined to correctly install a slate roof. An educated non-roofer can easily do a better job of it than a non-educated roofing contractor. In Traditional Roofing #5, all the installation mistakes shown were caused by roofing contractors, some of whom fit my unflattering descriptions perfectly. It's a shame that so many new slate roofs are going into litigation. We've been installing slate roofs here in the United States for 150 years and many of the century-old roofs are still functioning quite well today. We already know how to install these simple roof systems, so why are so many of them being screwed up? My article about the sexagenarians illustrates the point that slate roofs are not difficult to install and could be properly installed by even roofing contractors if they cared enough about their trade to educate themselves beforehand.

**NUMNUTS?** — *One of your readers was upset that you denigrate unqualified roofers. As an unqualified roofer, but with many years of historic work behind me, I offer the following: several years ago I was asked to look at the roof on a 100+ year old church. The roof had originally been slate, but a local roofer not many years prior had installed asphalt shingles. The asphalt roof not even 10 years old was obviously wearing out. It had been installed over the slate — not one slate had been removed and the asphalt shingles were power nailed through the slate and through the deck boards. When I tapped the underside of the slate it rang clear, an indication that they had a good slate roof to start with — only now it had a lot of extra holes in it. The church had, in effect, taken a repairable 100 year roof and at considerable expense turned it into a 15 year roof... that is, if they would be so lucky for the asphalt shingles to survive that long. Last I heard they wanted to use plastic slate for their next experiment. Now... my question is what exactly do we call the numnuts that sold the church on an asphalt shingle roof installed in this manner?*

**TR** — I think the term "numnuts" is grammatically correct.

**SLATE OVERHANG AT DRIP EDGE** — *I'm working on a job where half-round copper gutters were installed on a house with a new slate roof. There is a very small overhang (1/4" to 1/2") on the slate roof and some water drips down the fascia board and behind the half round gutter. Is there a standard amount of overhang for the slate roof? How far below the edge of the slate should the gutter be installed? Should flashing have been installed below the slate to "direct" water in to gutter?*

**TR** — Slate typically overhangs 1.5" at the drip edge. Gutters should be low enough that the plane of the roof will shoot over the top outer edge of the gutter. Metal drip edge along the fascia is not usually necessary. The correct slate overhang at the eaves (1.5") prevents water from running down the fascia.

**WIDELY VARYING ESTIMATES** — *I had a reputable roofer give me an estimate. He said the slates were very high quality and in good condition and could last another 50 years. However, he said that the slating nails were not copper nails and had rusted through and this necessitated the removal of all slates, placing an underlayment and reroofing the slates with copper nails. This process would cost about \$37,000.00. As I suffered from sticker shock, I did some research on the internet, discovered your site and contacted some slate roof experts who came out to do an estimate and who told me that several slates needed to be replaced and gave me an estimate of roughly \$3,500.00, a difference of more than \$33,000.00. I am now quite confused. I am wondering how I should proceed.*

**TR** — The first estimate is unrealistic. I have never seen a situation where an entire American slate roof needed removed and reroofed because of nail failure. If the slates are still good enough to reuse, then the nails are probably also still generally good. I discuss this issue in my book, the Slate Roof Bible and even show photos of very old, but still good, non-copper slating nails. When a contractor gives that sort of advice, it's immediately a red flag, strongly indicating they don't know what they're talking about. If you allowed them to remove your roof and reslate it, you'd probably end up with a bum job and be worse off than you are now, and a lot poorer. Unfortunately, there are lots of contractors out there who know little about slate roof restoration, which is a speciality trade that requires years of experience, and instead they routinely condemn good slate roofs and convince the owners that the roofs have to be completely removed and replaced. At least some property owners, like yourself, are now getting online and doing some homework before being hood-winked. The second estimate is probably correct.

**LEAKING CHIMNEY** — *I have your book, the Slate Roof Bible, and it is great. However, I have a leak in my slate roof around the chimney. To date, I have paid three different people to re-flash the chimney and I STILL have the leak. The damage is mounting and 7 different roofers (who ostensibly "do" slate) can't find the leak. I am at wit's end.*

**TR** — Are you sure the chimney is leaking and not simply condensing moisture inside? If the flashing is leaking, the moisture will show up when it's raining and it will only be seen on the leaking side. You can verify this by going up inside the roof during a rain and looking for water entry. If the chimney is condensing, it will show up primarily in the winter or whenever the chimney is being used. Water may be seen on all four sides, or even on a lower floor. Condensation inside old chimneys is a common phenomenon. It occurs during cold weather when warm flue gasses cool and condense near the top of the chimney. Flue gasses can be high in water content and the water will soak the inside of the chimney, eventually finding its way through the bricks and into the building, appearing to be a leak. This sort of leak can be solved with a chimney liner.

**HANGING GUTTERS** — *I never had gutters and have lived in my 3-story house for 36 years. Since I've been having more and more problems with water in my basement, I figured gutters may help. My question is, should there be a special way the contractor installs gutters since the roof is slate? I just had an estimate and the contractor said he doesn't believe there is a difference in the installation and I have a bad feeling about this so, before I sign the contract, I'm trying to do some research on this.*

Continued On Page 34

# TIPS & TECHNIQUES FOR SOLDERING COPPER

Christopher Paulin, President, The Paulin Slate & Copper C<sup>o</sup>

**1. MAKE YOUR SEAMS TIGHT & CLEAN** — Clean and tight seams are essential: solder much prefers bright copper with a very close fit. Lap seams should have a minimum 1" overlap and no gaps larger than 1/16". Install only as much copper as can be soldered by the end of the day. Sloppy or dirty seams take much longer to solder: the extra time spent making a clean seam will pay dividends when soldering. Figure 1 shows what a good lap seam looks like, Figure 2 shows a good flat-lock seam.

**2. RIVETING MADE EASIER** — We carry self-drilling, metal lath, pan-head screws, size 8, about 1/2" long, in our pouches or rivet boxes — they hold the sheet or panel in place, can be easily removed, drill exactly the correct size hole for standard rivets, and can be reused indefinitely. Install the screws along the entire length of a lap seam working from the bottom to the top, then remove each one and replace with a rivet: you won't get copper shavings stuck between the sheets since they're held tight together. Put your drill bits back in the truck — you won't need them.

**3. PEEN DOWN YOUR JOINTS** — Even the best seams always have some gaps, slightly protruding rivet heads or irregularities which require extra attention. Use the well mushroomed head of a wide brickset to gently tap lap seams and rivet heads flat, taking care not to dent the joint. The wide blade of the brickset is handy for getting corners of box gutters tight. We go over flat-lock seams first with a Nupla 4 lb. dead blow hammer and then again with a 2-3 lb. drilling hammer with a slightly convex face, hammering the leading edge of the overlying panel flush with the adjacent panel. This allows the soldering iron tip to more easily bridge the flat-lock seam.

**4. FLUX IT** — Get some Stay-Clean Liquid Flux by Harris: it works much better than Ruby Fluid. Don't dip your brush into the quart container or you'll dirty the whole quart: we decant a half-gallon at a time into a small glass container (baby food jars are great) and work from that. You can find Harris Stay-Clean at a good welding supply store (Airgas, etc.).

**5. GET YOUR IRON HOT** — Good soldering is done with the solder flowing in the liquid stage, not the plastic stage. The solder should look like you've laid a ribbon of liquid mercury on the copper (see Figure 3). If you're getting ridges in the finished solder, turn up your iron and slow down.

**6. KEEP YOUR SOLDER CLEAN** — Solder bars are a bit like welding electrodes — they like to be kept clean and dry. If you leave the solder roll around in your truck or gang box, you'll get impurities on the bars which will accumulate on your iron tip and require extensive cleaning.

**7. DIP YOUR TIP** — Here's how to make yourself a good iron dip: combine 3 parts tap water with 1 part Ruby Fluid in a medium sized glass pickle jar with a tight fitting lid. Quickly dip your hot soldering iron tip in this mixture after soldering each joint and watch the dross come right off, leaving the tip clean and bright — no more brushing or wiping or cleaning with sal ammoniac. Also useful for cooling down your iron if it gets too hot. Figure 4 shows iron dip & flux jars.

**8. USE AN ELECTRIC IRON FOR VERTICAL JOINTS** — We use a 550-watt American Beauty soldering iron w/ chisel tip for soldering our vertical joints: if you hold the iron perpendicular to the joint, press the tip into the seam and work from top to bottom, the joint can be soldered beautifully in one pass. The vertical joint in Figure 5 was soldered with an electric iron. Since these irons are engineered for shop work, they don't get hot enough in ambient temperatures below 65 deg F. and, under those conditions, we revert to propane fired irons.

**9. USE YOUR IRON CORRECTLY** — Both lap and flat-lock seams should be soldered in one pass with the hot iron placed across the joint so that the most heavily massed part of the tip is on the folded or "high" side of the seam. Remember the heat is transmitted from the soldering iron tip to the seam through the puddle of molten solder bridging the joint, so as in welding, watch your puddle and work along continuously.

**10. WASH YOUR JOINTS** — If joints are not washed properly after soldering, the flux remains active and will leave a green discoloration on the adjacent copper. We keep a pump sprayer filled with tap water and a few squirts of dish soap, and spray joints and adjacent copper copiously and scrub thoroughly. This works quite a bit better than the usual baking soda/water scrub. The sprayer acts as an emergency fire extinguisher as well. The sprayer & soldering outfit are shown in Figure 6 at left.

[For more about Paulin, see Project Spotlight on page 22.]

All photos by Christopher Paulin.



Figure 1



Figure 2

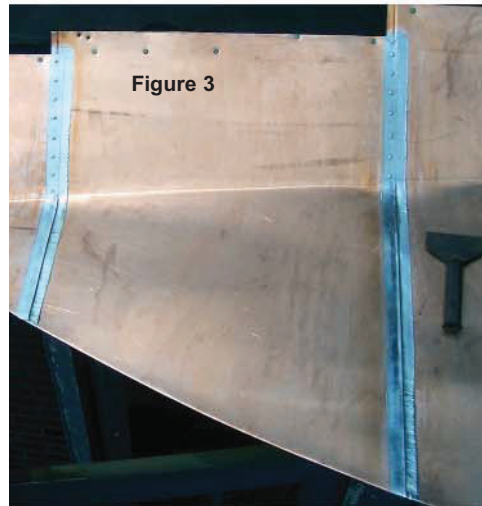

Figure 3

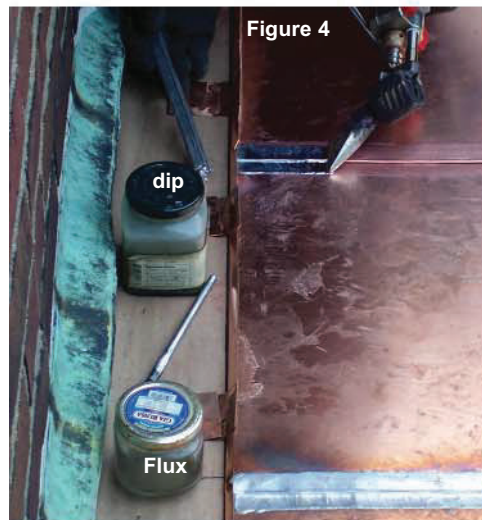

Figure 4

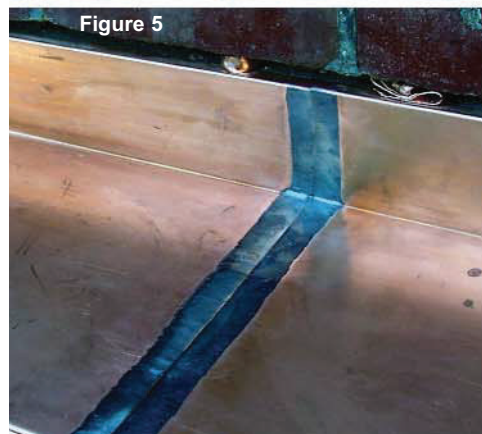

Figure 5



Figure 6

# Generation-X SLATERS

Slate roofing is considered to be a tradition passed on from father to son, generation to generation. For this reason, commodity roofers (as a whole) usually don't even consider slate roofing as a source of revenue or income. Also, slate has been labeled as too specialized, too expensive, too difficult, not as popular, time consuming, etc. It's just not mainstream enough for your average roofer.

Recent storms and natural disasters have forced this stereotype of slaters to change. Instead, companies are now starting to break into a market that was relatively dominated by the seniors and traditionalists. One company that has taken the market by storm is Midwest based company CMR Construction & Roofing (CMR). Through hurricane Katrina and a big late spring hail storm in Indianapolis, CMR has become a premier slate installer in the Midwest. According to one of the most productive slate roofing quarries in the nation, CMR was considered its major purchaser. No longer is slate roofing only for the families that have been doing this for generations, but for a new cross-over commodity breed.

A new generation-X of slaters is emerging. Slate has helped catapult CMR into a growth explosion of about 3,000% in the last 3 years. CMR has been labeled as the 30th fastest growing company in the nation,\* 3rd in the "construction" field,\* and the 27th largest roofing contractor in America.\*\* Slate has played an integral part to their success.

CMR has gained the experience to understand the properties of slate, assess its complexities, and properly execute its application. CMR believes that slate is such a beautiful and timeless material, that its co-existing partners should play the same role. Meaning that the other materials such as the valleys, flashings, underlayments, stucco, etc. (essentially the other parts of the roof) need to be just as elegant and properly installed.

CMR has gained great experience over the last few years, having been called upon to play the role of leaky slate roof problem solvers. They have had to trouble-shoot and undo the poor craftsmanship of those contractors who are less than credible and reputable. They find that most roof leaks are due to improper flashing practices and failure to replace old flashings (when doing repairs or new roofs due to degree of difficulty or lack of knowledge).

CMR Construction & Roofing LLC recommends a few of the following tips:

- Replace all old flashing during installation regardless of location or difficulty.
- All copper joints should be soldered (i.e. crickets, opposing valleys, dormer shelves, and pans) instead of silicone only.
- Hang slate around copper flashing with copper wire instead of nailing through the copper and jeopardizing the integrity of the flashing.

The implementation of these slate roofing standards has allowed this generation-X company to become a leader in an industry once dominated by the generations of traditional roofers. Slate's beauty affects everything around it. It makes the roof more elegant, the property more beautiful, and the neighborhood timeless. For CMR Construction & Roofing LLC, slate has helped them grow, thrive, and shine. ☑

\*Inc. Magazine 2007 \*\*RSI Magazine 2007

**Left: Dyllon Marsof of CMR Construction**

Photo by Joseph Jenkins



## SLATE ROOF SPECIALISTS

## TILE ROOF SPECIALISTS

## STORM DAMAGE ANALYSIS

**CMR Construction & Roofing has taken the slate market by storm. They were considered to be last years largest slate buyer in the nation. They have become the 27th largest roofing contractor in the nation, and the third fastest growing privately held construction company America! CMR offers a variety of services for commercial and residential projects. For more information, please visit:**

**[www.CMRconstruction.com](http://www.CMRconstruction.com)**  
**or call toll free: 877-EZ-ROOF-1**

■ ROOF	■ CUSTOM	■ LICENSED
■ SIDING	■ CONSULTING	■ INSURED
■ GUTTERS	■ RESTORATION	■ BONDED
■ COPPER	■ MAINTENANCE	■ CERTIFIED

SLATE ROOFING CONTRACTORS ASSOCIATION

NATIONAL ROOFING CONTRACTORS ASSOCIATION

# The Timeless Beauty of Natural Slate®

Slabs for Counter Tops ■ Wall Cladding ■ Flooring ■ Roofing ■ Paving



**Baltimore, MD**  
410-325-2663

**Walnut Creek, CA**  
925-210-1042

**San Francisco, CA**  
415-864-7813

**Los Angeles, CA**  
310-855-0594

**Newport Beach, CA**  
949-650-2200

**Solana Beach, CA**  
858-259-1343

**Seattle, WA**  
206-938-3718

**Boynton Beach, FL**  
561-742-0200

**Los Altos, CA**  
650-559-8900

**Vermont Products**  
518-642-1748

**Midwest**  
800-553-5611

**East Coast**  
866-206-9524



**American  
Slate  
Company**

**The Experts in Slate®**

Mon-Sat: 8am-5pm

[www.americanslate.com](http://www.americanslate.com)



## Gough SnoGuards™

4133 DuBois Boulevard  
Brookfield, IL 60513  
(708) 485-6272  
[sales@SnoGuard.com](mailto:sales@SnoGuard.com)

Help Keep Snow From Avalanching From Your Roof - Help Protect Pedestrians, Roofs, Gutters & Landscaping Below

- For slate and tile roofs
- Asphalt and wood
- Copper and metal roofs
- New construction and retrofit



Type SGAR  
for slate, copper & asphalt



Type SGAR-SLS  
with slotted strap for slate retrofit

*An original, traditional,  
strong snow guard  
used since 1930  
- over 77 years*

- Free layout
- Most adaptable

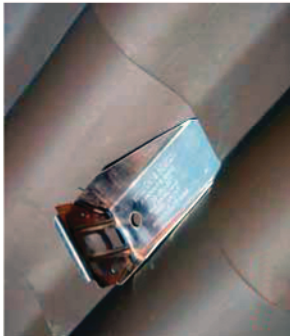

Type SGSP  
for Ludowici Spanish tile

Installed on countless churches, schools, village halls, libraries, museums, businesses and fine residences from Chicago's Holy Name Cathedral to residences in the mountains of Utah and Colorado to the copper dome of Utah's Supreme Court Building and in the New England area.



Type SGBK  
for Ludowici book tile



Type SGNL Exclusively ap-  
proved for Nu-Lok slate system

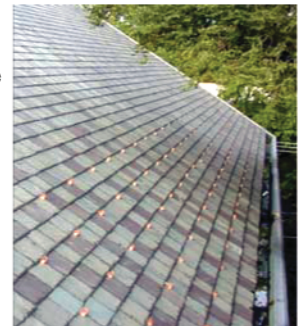

Type SGAR-SLS  
for retrofit on slate

[www.SnoGuard.com](http://www.SnoGuard.com)

# What the

# HAIL?

Joseph Jenkins

HAILSTONES usually consist of water ice, measuring between 1/4" and 2" in diameter (the size of a small pea to the size of a golfball), with larger stones coming from severe thunderstorms. It forms on dust, insects, or ice crystals when supercooled water freezes on contact. Once a hailstone becomes too heavy to be supported by a storm's updraft it falls out of the cloud. When a hailstone is cut in half, a series of concentric rings reveals the number of times the hailstone had traveled to the top of the storm before falling. Hail can sometimes grow to 6" and weigh more than half a pound. It can do serious damage to cars, skylights and crops. Massive hailstones have caused concussions and fatal head trauma. The last known hail fatality in the United States was Juan Oseguera, a 19-year-old who died after being hit in the head by a softball sized hailstone in Lake Worth, Texas on March 29, 1990. Hail-producing clouds may be green in color.

Hail damage to a slate roof is easily identifiable. Although slate tends to be durable and resistant to hail damage, there are three primary conditions that will maximize hail damage to such a roof: 1) very large hail; 2) thin, soft or deteriorated slates that are relatively fragile (such as older Pennsylvania soft black slates); and 3) slates installed in a "side-lap" style where much of the roof has only a single layer of slate. The combination of unusually large hail and unusually fragile slates, especially on a "side-lap" slate roof, creates the highest expectation of slate roof damage.

Hail is frozen water propelled through the air by the force of wind and gravity and it can damage a slate roof upon impact. The effect of that impact is to either break or puncture the slates and/or dent metal flashings. In general, slates can be perforated by objects either from inside or outside a roof. Two common examples of impact damage from inside a roof include bullets shot through a roof from the interior of the building, often seen on barn roofs where farmers shoot at pigeons in the rafters, and nail heads in the roof deck working loose and slowly pushing

through the slate above. External impacts include hail, rocks, golf balls, bullets shot from outside, etc. Both types of perforations are different and easily identifiable. When slate is perforated, the impact leaves a clean hole on the impact side and a cratered hole on the opposite side of the impact (Figure 1). Therefore, by looking at the hole, one can easily determine whether the impact originated from outside or inside.

Another way to assess the amount of hail impact on a roof is to examine the metal components for indentations. For example, Figure 2 illustrates hail impact indentations on low-slope copper roofs after severe hail events. These roofs are in New Orleans and Chicago. Figure 3 illustrates hail damage to a graduated slate roof in Indianapolis. Although the slates were 1/2" to 3/4" thick Vermont slates only 75 years old, some were perforated by huge hail stones.

Although hail can damage a slate roof, in most cases the roof can be repaired. I looked at a 100 year old Vermont sea-green side-lap barn roof after a severe hailstorm and, looking up from inside, it looked like a planetarium — points of light were everywhere. But a day's work for a couple experienced slaters replaced all of the perforated slates.

The larger problem with hail events is that roofing contractors with little experience working on slate roofs and who see money to be made on an insurance claim will condemn a roof that has been hail damaged rather than propose to repair it. Many good slate roofs have been lost this way. Part of the fault lies with insurance companies who are quick to fork out money to have a slate roof replaced before getting an expert opinion on the roof's actual conditions. It's possible that soft slate on an old roof that has been impacted by large hail could be fatally damaged, but in most cases, hail damage on a slate roof should simply be repaired.

Such repair involves the replacement of damaged slates, which can be either perforated or broken. In some cases, damaged flashings may also have to be replaced. When replacing damaged slates, the replacement slates should be of the same size (length, width and thickness), type (i.e. origin, such as Vermont sea-green), shape (e.g. square cornered, beveled, scalloped), and approximate age, as new slate rarely blends in well on an old roof, with a few exceptions. ☒

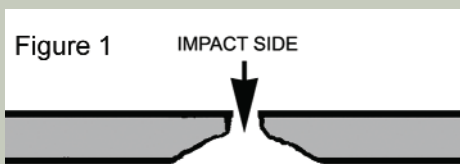

**Figure 1** IMPACT SIDE  
The side of the slate opposite the impact side breaks out and leaves a crater. The impact side has a clean edge and no crater.

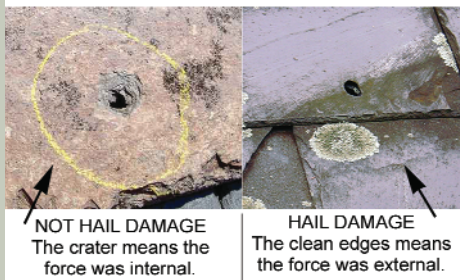

All photos by Joseph Jenkins.

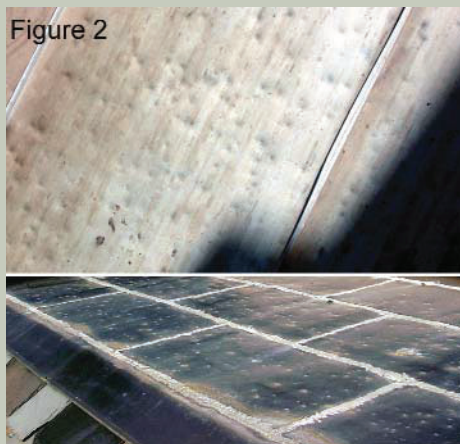

**Figure 2**  
▲ Hail impact indentations on metal roofing is not typically a cause of leaks and can often simply be ignored.



**Figure 3**  
▲ Hail-perforated slates should simply be removed and replaced. Hail damage is rarely a cause for the replacement of an entire slate roof.



**JOHN STORTZ AND SON, INC.**

210 Vine St.,  
Philadelphia, PA 19106

Phone: 215-627-3855  
or 888-847-3456  
Fax: 215-627-6306  
Email: john@stortz.com

[www.stortz.com](http://www.stortz.com)

Manufacturer/Distributor of Slate Rippers, Hammers,  
Cutters and Sheet Metal Roofing Hand Tools.

YOUR UNLIMITED RESOURCE FOR

## SLATE AND TILE



**DOUG COCHRAN, President**

4001 Kennett Pike, Suite 134 #213, Greenville, DE 19807

PH: (302) 369-9187 FX: (302) 397-2742 Mobile: (302) 388-1155

Doug@ReclaimedRoofs.com  [www.ReclaimedRoofs.com](http://www.ReclaimedRoofs.com)



**1-800-347-9529**

Springfield, MA

[www.MAHANSLATE.com](http://www.MAHANSLATE.com)

Serving the New England Area

Providing quality service since 1979.

Customer satisfaction is always  
our first priority.

Residential - Commercial - Institutional



Check us out on the web for plenty of photos of our work.  
[www.MAHANSLATE.com](http://www.MAHANSLATE.com)

# GS RESTORATION SERVICES

WE SERVICE:

NEW HAMPSHIRE

PENNSYLVANIA

CONNECTICUT

NEW JERSEY

NEW YORK

VERMONT

MAINE.

## SLATE AND TILE WORK

ALL TYPES COPPER, TERNE METAL AND ZINC COATED FLASHING WORK

NEW COPPER ROOFS AND REPAIRS - STANDING SEAM AND FLAT LOCK

NEW BOX AND YANKEE GUTTERS INSTALLED OR REPLACED

GUTTER AND LEADER WORK - NEW AND REPAIRS

NEW COPPER ICE (BELTS) SLIDES

STEEPLE WORK

"We are dedicated to the  
preservation of our  
churches, buildings  
— commercial and  
residential, and their  
significance to our  
communities."

Spencer Powers,  
President

P.O. Box 501 (9021 Oakland Rd.)

Port Byron, NY 13140

Office phone: 1-800-399-0577

Fax: 315-776-8749

[gsrestoration@hotmail.com](mailto:gsrestoration@hotmail.com)



All photos this page by Joseph Jenkins

**OLD CHIMNEYS ON SLATE ROOFS** can be problematic when the flashing has worn out and the chimney is no longer in use. The solution is to remove the chimney top and “erase” the chimney from the roof. **1) Set up a safe scaffolding system** around the chimney using hook ladders, ladder jacks and planks. Remove the chimney top down to the roof. **2) Tear out** the old flashing and remove all broken, partial, or tarred slates. Take the chimney down below the roof. Lay a slate over the hole as a cover. You may have to scab some 2x4s on the rafters at this point to allow for nailing the replacement roofing boards. **3) Nail or screw roof boards** into place to cover the hole. Use the same type of lumber that the roof is made of (in most cases, 1” boards). The boards must be the same thickness as the existing roof decking. **4) Install the replacement slates.** Try to use the same type, size, shape and age as the existing slates and reuse the existing slates as much as possible. **5) Finish the slating,** first one side, then the other. Finally, install a new ridge section. The chimney removal should be almost invisible when done. This same procedure can be used to remove most roof penetrations on a slate roof. 

*GET RID OF  
THAT OLD  
CHIMNEY!*

Add the ridge to finish the job.

5

*Tis the season!*

# Copper Snowguards — What's New

Let it snow! Snowguards will keep the white stuff from sliding off your roof in an avalanche and banging up whatever's underneath. Two new lines of snowguards have recently been introduced and two existing brands remain popular. Let's start with the new ones.

**S&S COPPER PRODUCTS**— Salvo and Sons has introduced a new line of copper snowguards, including three different styles, one of which is shown at right. The snow guards were designed in-house and tested not only by S&S but also at the laboratories of Tox Pressotechnik in Warrenville, IL. All of the snow guards can be used on all roofing applications. See Salvo's ad on page 32, or contact them at Salvo and Sons, Inc., 1467 Aurora Way, Wheaton, IL 60187; Phone: 630-588-1932; Fax: 630-588-1933; [www.sandscopperproducts.com](http://www.sandscopperproducts.com).

**BACKYARD INNOVATIONS, INC.** is reintroducing the SnowTrapper™ snow guard for slate roofs (see sample at right). The patented inter-locking design optimizes structural strength and stability while maintaining aesthetically attractive looks. They were invented in 1995 and entered the commercial market in 1998. More detail is available at [www.snowtrapper.com](http://www.snowtrapper.com). You can direct inquiries to Melissa Lee, President, Backyard Innovations, Inc., P.O. Box 211563, St. Paul, MN 55121-1563, Ph: 651-686-0784 (work) or 651-389-9161; [sales@snowtrapper.com](mailto:sales@snowtrapper.com).

**GOUGH SNOGUARDS**® — F.C. Cody originally patented and manufactured this classic “snow-guard” in a shop eventually bought by Earl Gough who continued production as the Gough SnoGuard®. This is a classic snow guard, proven for over 77 years. When needed, Gough will provide an opinion for a layout design based on calculations and the experience of installing for over 31 years. Contact Earl Gough, 4133 DuBois Blvd. Brookfield, IL 60513; Ph: 708-485-6272; Cell: 708-878-3375; Fax: 708-485-6273; Email: [Sales@SnoGuard.com](mailto:Sales@SnoGuard.com).

**MULLANE SNOWGUARDS** — The M.J. Mullane Co. snowguard line was bought out by Berger Brothers in 2006 and is still widely available and popular. These snowguards are made of copper and classic, durable cast bronze, with a traditional 19th century design, manufactured with 21st century engineering. Berger products are distributed by [slateroofcentral.com](http://slateroofcentral.com), ph: 814-786-9085.

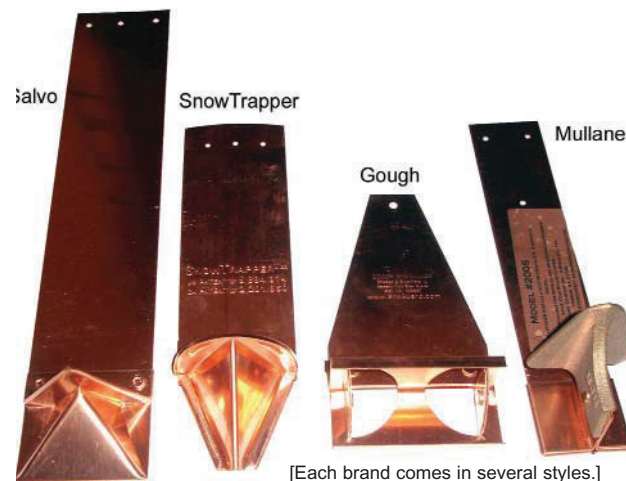

[Each brand comes in several styles.]

**ALL OF THESE SNOWGUARDS ARE AVAILABLE FROM SLATEROOFCENTRAL.COM. CALL US TOLL FREE AT 866-641-7141.**

# METAL DRIP EDGE

## for Slate Roofing

“Drip edge” is metal edging that is installed on the bottom edge of the eaves (which is also called the “drip edge”) where water drips off the roof. The metal product was primarily invented and widely manufactured to accompany asphalt shingle installations because asphalt shingles have little structural integrity and will sag over the edge of a roof if allowed to extend beyond the roof edge. Of course, the shingles *must* extend beyond the roof edge in order to allow the water to drip off the roof rather than run down the side of the building. Since asphalt shingles cannot extend beyond the edge of a roof without support, metal “drip edge” was invented to provide that support — to hold the shingles up so they don’t sag.

Slate shingles, being stone, will not sag over the edge of a roof. They, therefore, do not require a metal drip edge for support and such edgings have never been traditionally used on American slate roofs, except in certain limited situations. These situations may include when a slate roof ties into some types of metal roofs, or perhaps when it ties into some types of built-in metal gutters. Metal edgings have also been used on slate roofs for stylistic reasons — for decoration. In general, however, metal drip edges are not needed on slate roofs.

Then why use a metal drip edge? For three basic reasons:

1) Today, many slate roofs are installed by roofers whose primary work has been with asphalt shingles. They often use decking materials that would be considered sub-standard when compared to traditional wood board slate roof decks. Such sub-standard decking materials include plywoods, particle boards, OSB, and anything that is held together with glue. These decking materials are not as durable as wood boards and can benefit by having their exposed edges protected by a metal edging, both at the drip edge and along the sides of the roof (also known as the gable edges or rakes). Therefore, metal drip edges have become popular for slate roofs among some roofing contractors.

2) In addition, some contractors and building owners like the look of a copper edging on a roof system. It adds a rich appearance that complements the slate and the copper flashings. The small additional cost of copper roof edgings can add a measure of protection as well as additional quality to a slate roof installation.

3) When copper roof edgings are used on a slate roof installation, the standard wooden cant strip that is required at the starter course along the eaves can be completely eliminated and replaced with a copper roof edging that has the cant built right into it. This creates a permanent copper cant strip that is quickly and easily installed. Many inexperienced roofers forget to install the cant strip in the first place. By using a copper edge with a built-in cant, they can’t go wrong (no pun intended).

Are slate roof drip edges different from standard asphalt shingle drip edges? YES! Standard asphalt shingle drip edges are designed to prop up the shingles so they don’t sag over the edge of the roof. Slates don’t sag, but they also don’t lie flat on the roof surface like asphalt shingles. Every slate is lying at an angle on the roof. This means that the part of the metal edging that extends up the roof deck will be serving no support purpose on a slate roof because such an extension will not even come in contact with the slate. The rigid slate shingles create their own “drip edge” so the metal edging’s primary purpose is to protect the roof edge, not support the shingles. Therefore, a slate roof “drip edge” will not have the horizontal lip that is needed on asphalt shingle drip edges. This does not mean that asphalt shingle drip edges with the horizontal lip cannot be used on slate roofs — they can. But a metal edging made specifically for slate roofs will not have the horizontal lip, which serves no practical purpose.

Joseph Jenkins, Inc. has designed slate roof edgings made of 16 ounce copper specifically designed for slate roof installations. Our decades of experience with slate roofing systems has enabled us to provide these edgings with the correct design for stone roof systems. ☒

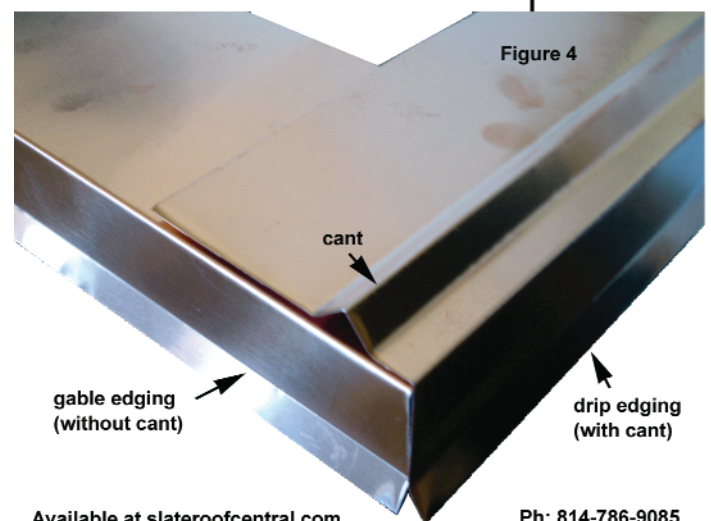
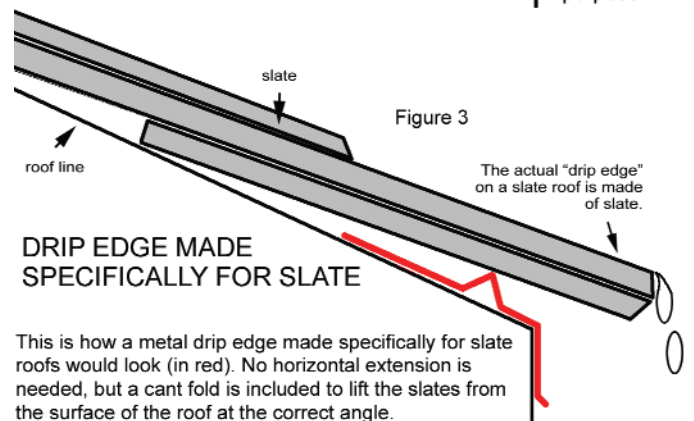
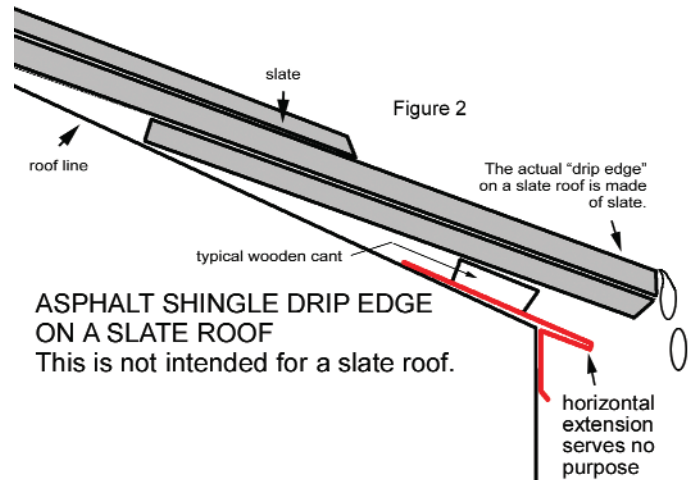
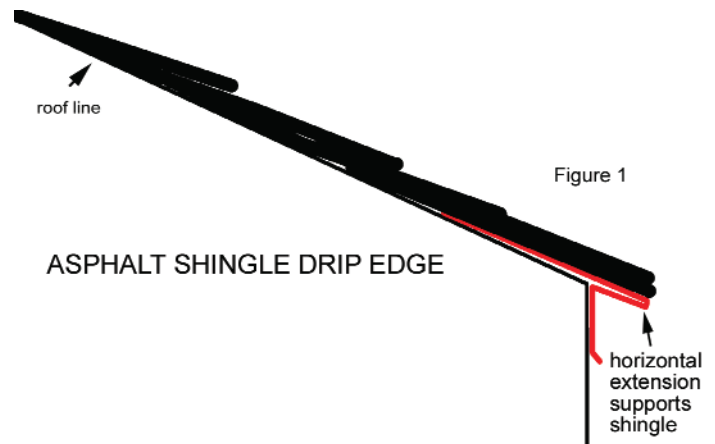

# APPRENTICESHIPS

in the Preservation and Traditional Building Trades  
**Pennsylvania Historical and Museum Commission**  
 Summer 2008

The Pennsylvania Historical and Museum Commission (PHMC) is sponsoring its 3rd annual summer apprenticeship program to introduce students and recent graduates of post-secondary trade schools, technical colleges and other training programs, and others with building trades experience, to the preservation and traditional building trades needed to preserve Pennsylvania's historic places. PHMC and several partner organizations and companies will be offering paid apprentice positions for 12 weeks in the summer of 2008 at locations throughout Pennsylvania. The apprenticeships will include a free training program with an introductory one-day seminar in historic preservation and two days of hands-on training by master craftsmen in various preservation and traditional trade skills

Applications will be due in April 2008. For information on the program contact Joe Lauver, Pennsylvania Historical and Museum Commission, by phone at 717-787-6242, FAX at 717-214-2988 or email at [jlauver@state.pa.us](mailto:jlauver@state.pa.us).

Visit our web site at [www.phmc.state.pa](http://www.phmc.state.pa)

**Alluvium Construction of NJ Inc.**  
 Restoration, Repair, New - [www.historicroofs.com](http://www.historicroofs.com)  
 856-767-2700 200 LAKESHORE DR. MARLTON NJ 08053

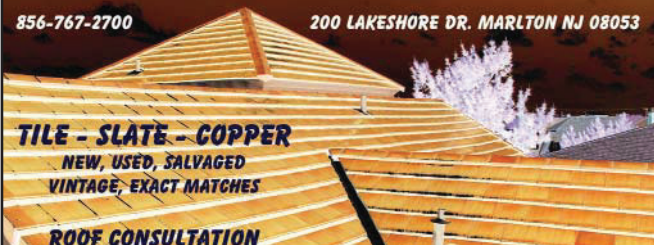

**TILE - SLATE - COPPER**  
 NEW, USED, SALVAGED  
 VINTAGE, EXACT MATCHES  
**ROOF CONSULTATION**



**HISTORICAL ROOF TILES**  
**Largest stock in U.S.**

- Our inventory dates to the late 1800s. It includes new tile and tiles no longer produced.
- We sell in all quantities and ship throughout the U.S. and also purchase salvaged materials

For a **FREE** brochure, write or call us today:

**TILE ROOFS, INC.**  
 9505 Corsair Road, Frankfort, IL 60423  
 (888) 708-TILE • fax: (708) 479-7865  
[www.tileroots.com](http://www.tileroots.com)

*"Your Tile, Slate, and Copper Roof Specialists"*

# Salvo and Sons, Inc



Salvo and sons, Inc is a family owned and operated Illinois roofing business. We have been installing specialty roofing in the Chicago land area for more than 24 years.

Salvo and Sons offers a wide variety of roofing services ranging from new construction installation to upkeep on any roofing system.

Feel free to call us or visit us at our web site at [www.salvoandsons.com](http://www.salvoandsons.com).

1467 Aurora Way  
 Wheaton, IL 60187

Phone: (630)588-1992  
 Fax: (630)588-1933



**S&S Copper Products**

S&S Copper Products was established by Salvo and Sons, Inc. S&S produces a variety of conductor boxes, finials, cupolas, vents, as well as our line of distinctive snow guards. Everything is made in house which ensures the highest level of quality.



30w270 Unit 110 Butterfield Rd  
 Warrenville, IL 60555  
[www.sandscopperproducts.com](http://www.sandscopperproducts.com)

**TR** — Smart to do the research. One of the ways slate roofs are damaged is by gutter installers nailing strap hangers through the slates. It's fast and easy for them, so they don't care if they put hundreds of holes in your slate roof and they assume you'll never know. At least not until the caulk wears off and your eaves start leaking. That's when you will pay a lot more money to have the slates along the eaves repaired than you would have paid if they had hung the gutters correctly in the first place. Use fascia hangers for your gutters, or install the strap hangers underneath the slates.

**HOOKED ON SLATE** — *I bought some slate this fall to put on the roof of my stone oven.*

*I've forwarded a picture of the completed oven. The copper work on the chimney was done by a friend of mine, I think it could have looked a little better, but it seems to function quite well (at least for now). I added a copper ridge cap after the picture was taken. I just love the roof, it turned out*



*nicer than I expected. The whole project was very enjoyable. I put it on myself and it took most of 3 days. I'm hooked on slate, I think it's a great product. I think I'll build a wood shed next summer.*

**LEAKING BOX GUTTERS** — *Our house was built in 1913 and has copper gutters and downspouts which are in terrific shape. On the third level the gutters are more flat and not half circle in design and have joints that seem to have been repaired. A painter suggested that the gutters be painted to seal the joints instead of simply repairing the joints themselves. What is your opinion with painting gutters rather than repairing the joints?*

**TR** — If the joints are bad and the copper is still good and clean (no tar or paint), then it's possible to resolder them, but difficult due to a number of reasons, mostly years of dirt and oxidation. The seams usually break due to a lack of expansion joints in the system, in which case, even if you do resolder them, the joints can break again. Paint will not seal leaks. You can seal the joints with trowel grade roof cement and fiberglass membrane, but having done that, there will be no way to resolder them. You can retroactively install expansion joints in box gutters, and resolder bad joints, but it's professional work.

**BURNING YOUR HOUSE DOWN SOLDERING** — *I did my first lock-seam copper roof this summer. I did all the soldering nervously with a propane torch, and next summer they want me to do the same thing*

*on the front porch roof, but I really think something of that size will give me too much opportunity to start a fire. So what I am asking is this: what size soldering Iron do you recommend for soldering flat lock copper roofs?*

**TR** — Open-flame soldering torches are notorious for catching houses on fire. Most people find out the hard way when they're soldering metal and the underlayment starts to smoulder. Of course, they don't see it because it's under the metal, so they'll wake up at 4 am to the smell of smoke in the house. If they do realize that they caught the underlayment on fire, they can't put it out without first ripping out the metal flashing in an insane frenzy. The solution is to use a closed-flame torch such as the Express, Sievert or Johnson (see page 7). Both the 300 and 550 watt American Beauty electric irons are quite nice, too.

**FAKE SLATE** — *It may interest you to know the series of events that lead me to a slate roof. My house was designed to have a natural color stainless steel shingled roof but during the two years of construction the price went from \$300/square to \$600/square. I then found a composite slate shingle which looks good, it's fire-proof, is guaranteed for 50 years and comes in all the colors we wanted and we were back to \$300 a square with a more natural look. It is listed as a top historical renovation shingle. I was a SUCKER! I have \$20,000 of garbage "shingles" sitting at my shop. The composite concrete shingles are already showing hair-line cracks and deterioration. After a little more research I found hundreds of lawsuits on this fake slate shingle. I have now joined many others in filing suit and will do everything I can to shut down that whole industry. My silver lining is that now I have real slate (at about the same price!) and I didn't install that garbage and find out 5 years from now.*

**TR** — A class action suit has been certified and the court has granted final approval to a Settlement for \$18.6 million with defendants, Re-Con Building Products, Inc., related to the manufacture and sale of roofing tiles and panels which are approximately 2/3 Portland cement and 1/3 wood cellulose fiber commonly known as FireFree Tiles and Quantum Panels. These products were marketed under the brand names, FireFree® Rustic Shake, FireFree® Quarry Slate, FireFree® Colonial Shingle, Quantum Shake, and Quantum Shake Panels, (collectively, "FireFree Tiles"). For more information, log into the web site at <http://www.firefreeclaims.com>.

**LAST BUT NOT LEAST** — *I was on a roof yesterday, and took this picture. The owner told me that he had a leak, and put in an insurance claim. The insurance company chose the contractor, a local fire and water damage company. This is their work! Nice! The owner admitted that it still leaked. B.B. Michigan*



**PRESERVATION • TRADES • NETWORK**

*"To empower traditional building trades through network, good works, community, fellowship and education."*

PO Box 249, Amherst, NH 03031-0249; Ph: 866-853-9335  
 Web: PTN.org; Email: [info@ptn.org](mailto:info@ptn.org). Membership fee is \$60.00 for individuals; \$80/family; \$25.00/student and \$300.00/corporation.

**JOIN THE PTN TODAY AND SUPPORT THE PRESERVATION TRADES!**  
 Host of the annual International Preservation Trades Workshops (IPTW)

# The Twelfth Century Slate Roofing Company

*Slate Roof Specialist*

Douglas L. Raboin  
10 Spring Valley Road  
Burlington, Massachusetts 01803  
Ph: (617) 666-3888; MA Reg.# 100693



# APRONS AND CLEATS

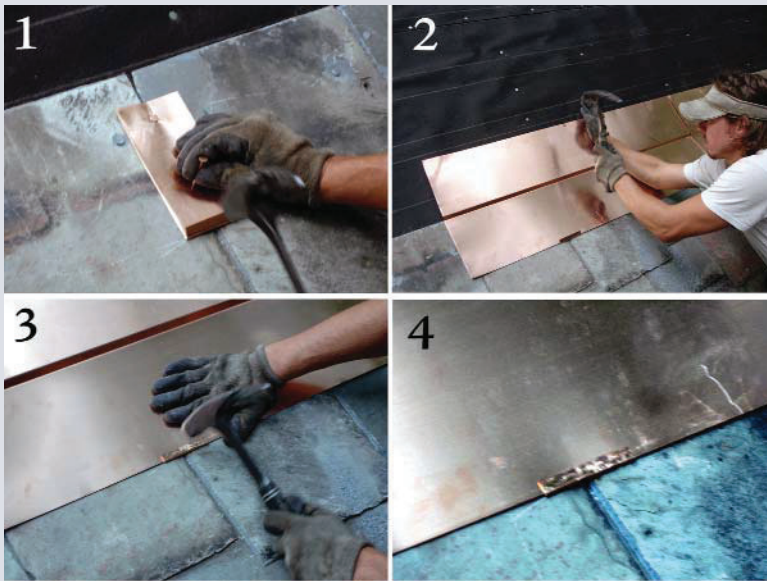

▲ A slope transition on a roof plane often requires a transition flashing, sometimes called an "apron." The flashing is folded with a Z bend to compensate for the angle of the slate on the upper half (making a cant strip unnecessary), and is nailed along the top edge, then held down along the lower edge with cleats, as shown. Dimensions vary, but 16", 20 ounce copper stock is shown used above.

▼ Unique slate siding and copper roofing installed by SRCA member Ron Kugel of Evans City, PA.

Top photos by Joseph Jenkins, bottom photo by Ron Kugel



# SNOW RAILS

Snow rails are used along the perimeter of slate roofs for the prevention of sudden and unexpected ice and snow avalanches, which can damage people, cars, shrubbery and other property underneath. The rail system can also include stainless steel expanded metal to prevent slates and other debris from sliding off the roof under the rails and creating a fall hazard. Also, a standard field array of snow guards can be included on the field of the roof above the snow rail for maximum protection.

Snow rail fence brackets are installed parallel to, and approximately 24" to 36" from the eaves. The brackets should be spaced from 18-24" to no more than 42" - 48" apart, depending on the pitch of the roof and the expected snow load. It is recommended to use through bolts with a backer plate on the underside of the roof deck. Bronze, brass or stainless steel pipe is recommended, (copper water pipe should not be used). High snow load areas should use a three pipe system such as the Mullane 500. If a smaller system is used, then it should be supplemented with an additional snow guard array in the field of the roof above the snow rail.

The Mullane Model 500 three-pipe system includes a bracket of solid cast bronze riveted to a 1/8" brass plate. The bracket includes three 1.125" holes to allow the rails to pass through. The plate is custom sized to equal the size of a slate on the roof, and is installed in place of a slate, as if it were a slate. The piping is brass, 3/4" inside diameter (1.05" OD) and includes couplings and end caps as needed. The red brass pipes can be bought in 12' lengths. All the parts are sold separately, allowing for custom installations.

Snow rail bracket systems are permanent and sturdy, providing lifetime durability. Independent testing has shown that the Mullane 500 snow rail assembly will withstand almost 4,000 pounds of direct mechanical force; the rivets will not pull out or shear and the brass bolts will remain intact. Furthermore, bronze castings will not crack due to water or age. They aren't cheap, but you get what you pay for. You can roughly expect to pay about \$100.00 per running foot for a 3-rail Mullane 500 system, plus shipping and installation costs. Add another \$9.00 per foot for stainless steel expanded wire mesh (2007 prices — subject to change), used to keep smaller objects, such as slates, from falling through the rails. These and other snow retention systems are available at [slateroofcentral.com](http://slateroofcentral.com) (814-786-9085). ☒



See also the snowguard article on page 31.

## PENN BIG BED SLATE CO., INC. MINERS & MANUFACTURERS SINCE 1934

Roofing Slate, Structural Slate, Sills, Treads,  
Risers, Fireplace Facings, Floor Tile,  
Turkey Calls, Craft Slate, Blackboards, etc.  
**WWW.PENNBIGBEDSLATE.COM**  
email: [pennbbs@aol.com](mailto:pennbbs@aol.com)

MAILING ADDRESS:  
P.O. Box 184  
Slatington, PA 18080

QUARRIES:  
Slatedale and Pen Argyll

PHONE (610) 767-4601 • FAX (610) 767-9252

# Sheldon Slate

Products Company, Inc.



Quarriers and Manufacturers of the  
Highest Quality Vermont Roofing Slate.

*New York: 518-642-1280 Maine: 207-997-3615*

143 Fox Road

Middle Granville, NY 12849

*Visit our web site at: [www.sheldonslate.com](http://www.sheldonslate.com)*



# SlateRoofWarehouse.com

Slate Roofing Tools, Equipment and Supplies – Ph: 814-786-9085

## WE SHIP NATIONWIDE

Order online 24/7 or call us  
9-5 M-F eastern time.

Check our web site for our full inventory!



16 and 20 Ounce Copper Rolls

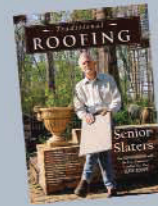

Traditional Roofing Magazine



Slate Roof Bible



Ladder Hooks



Rippers



Drip Edge

DROP EDGE WITH CANT GABLE EDGING (WITHOUT CANT)



Sheet Metal Hand Tongs



Stakes



Slate Cutters



Slater's Gloves



Tool Sets



Pipe Flashings



Tinner's Red and Green Paint



Copper and Stainless Nails & Rivets



Bench Furnace



Snow Guards



Copper Bird Houses



Tennsmith Equipment



Slate Hooks



Roof Jacks



Slate Roofing Shirts



Everything for Soldering



Slater's Hammers

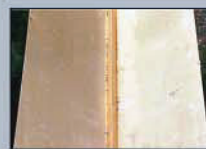

Copper Valleys



Electric Solder Trough

We have gift ideas for your favorite craftsman too. Take a look at our online gift section!

Joseph Jenkins, Inc.  
143 Forest Lane  
Grove City, PA 16127 USA

Prsrt Std  
U.S. Postage  
**PAID**  
Youngstown, OH  
Permit No. 225